

BÜNDIGFRÄSAGGREGAT – CLASSIC LINE LIVELLO

TECHNISCHE DATEN

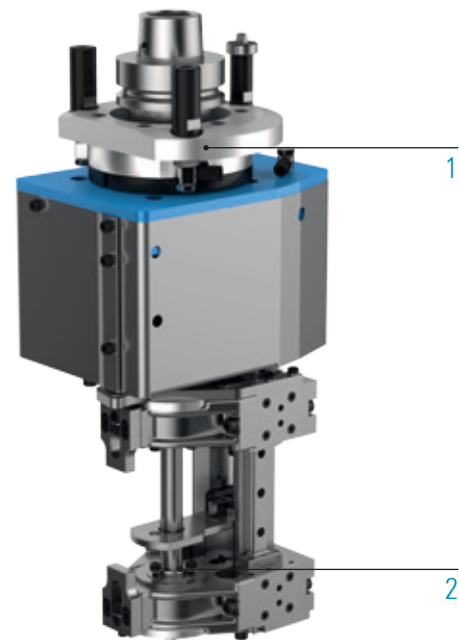

Schmierung	Fett
max. Abtriebsdrehzahl n_2	12.000 min ⁻¹
Übersetzung ($n_1: n_2$)	1:1
max. Abtriebsdrehmoment M_2	5 Nm
max. Kantenradius	R12
max. Werkstückdicke	60 mm
Gewicht	ca. 11 kg

STANDARDAUSFÜHRUNG

- 
 Maschinenanbindung
HSK - F63
- 
 Werkzeugaufnahme
Zentrier-Ø 19

WEITERE OPTIONEN: MODULARER AUFBAU

1



MASCHINENANBINDUNG



HSK - F63
Felder



HSK - F63
HOMAG / WEEKE /
WEINMANN



HSK - F63
IMA



HSK - F63
SCM



HSK - F63
Weinig

 Weitere Informationen S. 106

2

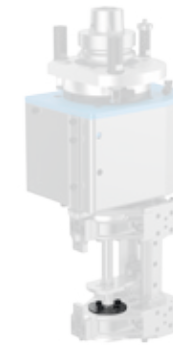

WERKZEUGAUFNAHME



Zentrier-Ø 19

 Weitere Informationen S. 108

BEARBEITUNG



Fräsen



Schleifen

SPEZIFIKATIONEN



Anzahl
Werkzeugaufnahmen



0°



180°

Achswinkel



360°

C-Winkel



Fettschmierung

VIDEO



Bündigfräsaggregat – live in der
Anwendung
QR Code scannen oder alternativ:
www.youtube.com/BENZWerkzeugsysteme

DIREKT BESTELLEN



Anfrageformular:
www.benz-tools.de/de/produkte