

# UNTERFLURAGGREGAT – CLASSIC LINE SUBIO

## TECHNISCHE DATEN

|                               |                          |
|-------------------------------|--------------------------|
| Schmierung                    | Fett                     |
| max. Abtriebsdrehzahl $n_2$   | 10.000 min <sup>-1</sup> |
| Übersetzung ( $n_1: n_2$ )    | 1:1                      |
| max. Abtriebsdrehmoment $M_2$ | 8Nm                      |
| Gewicht                       | ca. 7kg                  |

### STANDARDAUSFÜHRUNG

- 1  Maschinenanbindung  
HSK - F63
- 2  Vorsatzkopfgröße  
M
- 3  Werkzeugaufnahme  
Spannzange ER25A

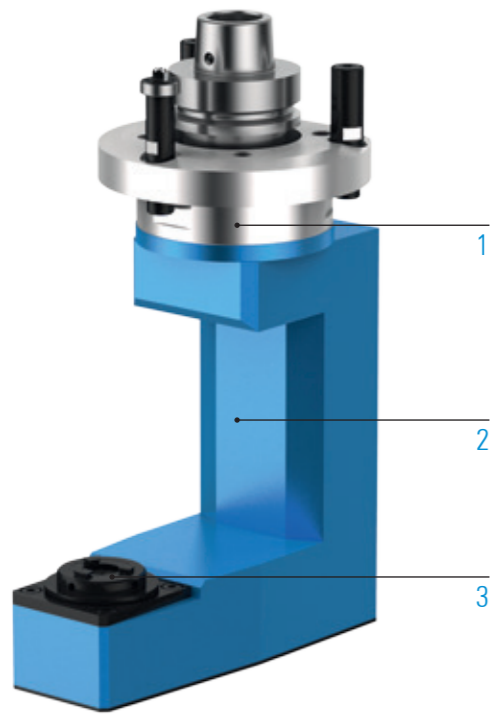

### BEARBEITUNG



Bohren



Fräsen

### SPEZIFIKATIONEN



Anzahl  
Werkzeugaufnahmen



Achswinkel



C-Winkel



Fettschmierung

### DIREKT BESTELLEN



Anfrageformular:  
[www.benz-tools.de/de/produkte](http://www.benz-tools.de/de/produkte)

## WEITERE OPTIONEN: MODULARER AUFBAU

1



### MASCHINENANBINDUNG



 Weitere Informationen S. 106

2



### VORSATZKOPFGRÖSSE



 Weitere Auskragungen und Längen auf Anfrage

3



### WERKZEUGAUFNAHME



Spannzange  
ER25A      Weldon Ø 12

 Weitere Informationen S. 108