

# SCHLOSSKASTENAGGREGAT – CLASSIC LINE FORTE

## TECHNISCHE DATEN

Schmierung	Fett
max. Abtriebsdrehzahl $n_2$	15.000 min <sup>-1</sup>
Übersetzung ( $n_1: n_2$ )	1:1,2
max. Abtriebsdrehmoment $M_2$	25 Nm
Gewicht	ca. 5,5 kg

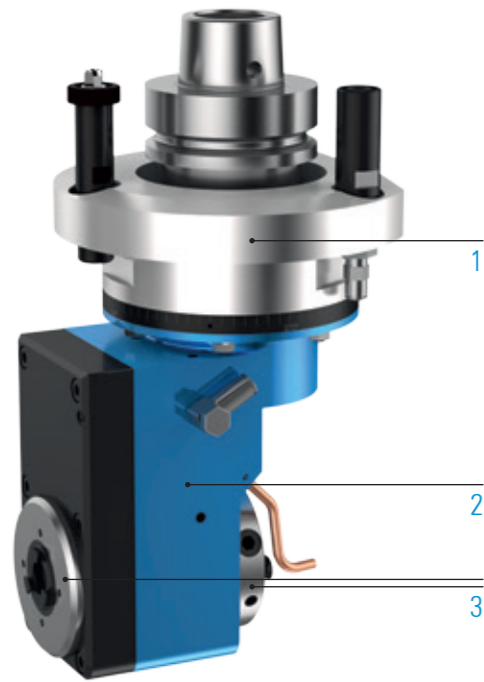

### STANDARD AUSFÜHRUNG

- 1  Maschinenanbindung  
HSK - F63
- 2  **M** Vorsatzkopflänge
- 3  Werkzeugaufnahme  
Zentrier-Ø 30/Whistle Notch Ø 16/Ø 20  
+  
 Spannzange ER16A

### BEARBEITUNG



Bohren



Fräsen



Sägen

### SPEZIFIKATIONEN



Anzahl  
Werkzeugaufnahmen



Achswinkel



C-Winkel



Fettschmierung

### VIDEO



Winkelkopf – live in der Anwendung  
QR Code scannen oder alternativ:  
[www.youtube.com/BENZWerkzeugsysteme](http://www.youtube.com/BENZWerkzeugsysteme)

### DIREKT BESTELLEN



Anfrageformular:  
[www.benz-tools.de/de/produkte](http://www.benz-tools.de/de/produkte)

## WEITERE OPTIONEN: MODULARER AUFBAU

1



### MASCHINENANBINDUNG



 Weitere Informationen S. 106

2



### VORSATZKOPFLÄNGE



 Weitere Informationen S. 107

3



### WERKZEUGAUFNAHME

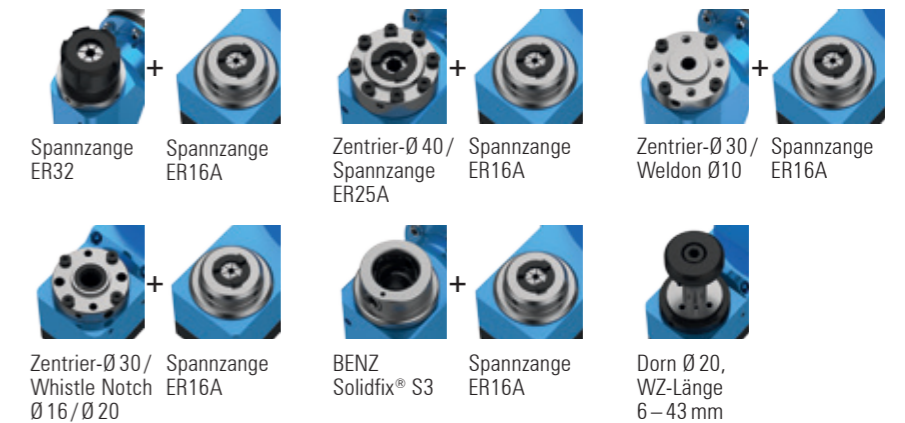

 Weitere Informationen S. 108