

PLN

Das perfekt abgedichtete geradzahnte Planetengetriebe, bietet Höchstleistungen und verliert nie die notwendige Steifigkeit

Unser geradzahntes Präzisions-Planetengetriebe ist für Höchstleistung und Drehmoment konzipiert. Die vorgespannten Kegelrollenlager des **PLN** und die von uns entwickelte Abdichtung garantieren optimale Performance auch bei Staub und Strahlwasser.

The perfectly sealed planetary gearbox with straight gearing delivers the maximum performance without ever losing the required stiffness

Our straight-toothed precision planetary gearbox has been designed for the highest performance and torque. The prestressed tapered roller bearings in the **PLN** and the seal we have developed safeguard the optimal performance even against dust and water jets.

Nenn-Abtriebsdrehmoment
Nominal output torque **27 - 1800 Nm**

Radialkraft
Radial force **3200 - 21000 N**

Axialkraft
Axial force **4400 - 21000 N**

Verdrehspiel
Torsional backlash **1 - 5 arcmin**

Schutzart
Protection class **IP65**

Baugrößen
Frame sizes

- 70
- 90
- 115
- 142
- 190

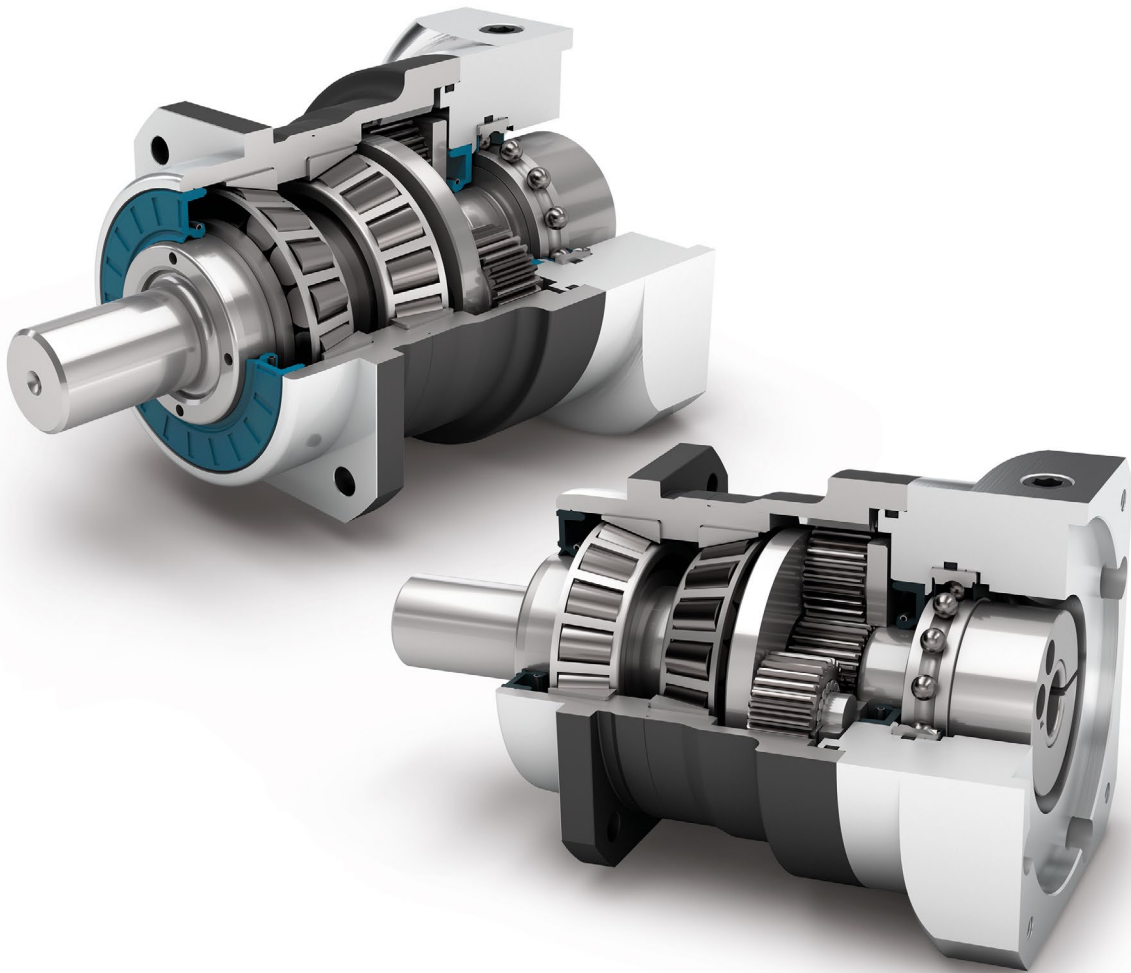

Precision Line
Precision Line

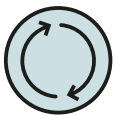

Drehrichtung gleichsinnig
Equidirectional rotation



Quadratischer Abtriebsflansch
Square type output flange



Radialwellendichtring
Rotary shaft seal



Planetenträger in Käfigausführung
Planet carrier in cage design



Option: Verzahnte Abtriebswelle (DIN 5480)
Option: Splined output shaft (DIN 5480)

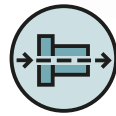

Koaxialgetriebe
Coaxial gearbox



Geradverzahnt
Spur gear



Vorgespannte Kegelrollenlager
Preloaded tapered roller bearings



Extra langer Zentrierbund am Abtrieb
Extra long centering collar



Option: Reduziertes Verdrehspiel
Option: Reduced backlash



Option: Planetengetriebe mit montiertem Ritzel auf Seite 140
Option: Planetary gearbox with mounted pinion on page 140

Detaillierte Erläuterungen der technischen Features ab Seite 169.
Detailed explanations of the technical features starting on page 169.

Code	Getriebekennwerte	Gearbox characteristics			PLN070	PLN090	PLN115	PLN142	PLN190	p ⁽¹⁾
	Lebensdauer (L _{10h})	Service life (L _{10h})	t _L	h	20.000					
	Lebensdauer bei T _{2N} x 0,88	Service life at T _{2N} x 0,88			30.000					
	Wirkungsgrad bei Volllast ⁽²⁾	Efficiency at full load ⁽²⁾	η	%	98					1
					95					2
	Betriebstemperatur min.	Min. operating temperature	T _{min}	°C	-25					
	Betriebstemperatur max.	Max. operating temperature	T _{max}		90					
	Schutzart	Protection class			IP65					
S	Standard Schmierung	Standard lubrication			Öl (lebensdauer geschmiert) / Oil (lifetime lubrication)					
F	Lebensmitteltaugliche Schmierung	Food grade lubrication			Öl (lebensdauer geschmiert) / Oil (lifetime lubrication)					
L	Tieftemperatur Schmierung ⁽³⁾	Low temperature lubrication ⁽³⁾			Öl (lebensdauer geschmiert) / Oil (lifetime lubrication)					
	Einbaulage	Installation position			Beliebig / Any					
S	Standard Verdrehspiel	Standard backlash	j _i	arcmin	< 3					1
					< 5					2
R	Reduziertes Verdrehspiel	Reduced backlash			< 2	< 1	< 1	< 1	< 1	
	Verdrehsteifigkeit ⁽²⁾	Torsional stiffness ⁽²⁾	c _G	Nm / arcmin	3,4 - 5,0	9,4 - 12,4	22,0 - 29,0	61,0 - 76,0	155,0 - 218,0	1
					3,4 - 5,0	9,0 - 12,4	22,5 - 29,5	61,0 - 78,0	169,0 - 224,0	2
	Getriebege wicht ⁽²⁾	Gearbox weight ⁽²⁾	m _G	kg	2,0	3,3 - 3,5	6,5 - 7,3	16,0 - 17,6	33,4 - 41,9	1
					2,5 - 2,6	4,1 - 4,3	8,2 - 9,0	21,4 - 22,0	45,4 - 49,6	2
S	Standard Oberfläche	Standard surface			Gehäuse: Stahl – wärmebehandelt und nachoxidiert (schwarz) Housing: Steel – heat-treated and post-oxidized (black)					
	Laufgeräusch ⁽⁴⁾	Running noise ⁽⁴⁾	Q _G	dB(A)	60	62	65	70	74	
	Max. Biegemoment bezogen auf den Getriebeantriebsflansch ⁽⁵⁾	Max. bending moment based on the gearbox input flange ⁽⁵⁾	M _b	Nm	18	38	80	180	300	

Abtriebswellenbelastungen	Output shaft loads			PLN070	PLN090	PLN115	PLN142	PLN190	p ⁽¹⁾
Radialkraft für 20.000 h ⁽⁶⁾⁽⁷⁾	Radial force for 20,000 h ⁽⁶⁾⁽⁷⁾	F _{r20.000 h}	N	3200	5500	6000	12500	21000	
Axialkraft für 20.000 h ⁽⁶⁾⁽⁷⁾	Axial force for 20,000 h ⁽⁶⁾⁽⁷⁾	F _{a20.000 h}		4400	6400	8000	15000	21000	
Radialkraft für 30.000 h ⁽⁶⁾⁽⁷⁾	Radial force for 30,000 h ⁽⁶⁾⁽⁷⁾	F _{r30.000 h}		3200	4800	5400	11400	18000	
Axialkraft für 30.000 h ⁽⁶⁾⁽⁷⁾	Axial force for 30,000 h ⁽⁶⁾⁽⁷⁾	F _{a30.000 h}		3900	5700	7000	13200	18500	
Maximale Radialkraft ⁽⁷⁾⁽⁸⁾	Maximum radial force ⁽⁷⁾⁽⁸⁾	F _{r Stat}		3200	5500	6000	12500	21000	
Maximale Axialkraft ⁽⁷⁾⁽⁸⁾	Maximum axial force ⁽⁷⁾⁽⁸⁾	F _{a Stat}		4400	6400	8000	15000	21000	
Kippmoment für 20.000 h ⁽⁶⁾⁽⁸⁾	Tilting moment for 20,000 h ⁽⁶⁾⁽⁸⁾	M _{K20.000 h}	Nm	191	383	488	1420	2535	
Kippmoment für 30.000 h ⁽⁶⁾⁽⁸⁾	Tilting moment for 30,000 h ⁽⁶⁾⁽⁸⁾	M _{K30.000 h}		191	335	439	1295	2173	

Trägheitsmoment	Moment of inertia			PLN070	PLN090	PLN115	PLN142	PLN190	p ⁽¹⁾
Massenträgheitsmoment ⁽²⁾	Mass moment of inertia ⁽²⁾	J	kgcm ²	0,216	0,560	1,942	7,008	22,876	1
				0,365	1,028	3,256	15,270	63,815	
				0,209	0,544	1,933	6,811	22,430	2
				0,249	0,699	2,373	9,813	36,003	

(1) Anzahl Getriebestufen

(2) Die übersetzungsabhängigen Werte sind im Tec Data Finder abrufbar – www.neugart.com

(3) T_{min} = -40°C. Optimale Betriebstemperatur max. 50°C

(4) Schalldruckpegel in 1 m Abstand; gemessen bei einer Antriebsdrehzahl von n₁=3000 min⁻¹ ohne Last; i=5

(5) Max. Motorgewicht* in kg = 0.2 x M_o / Motorlänge in m
* bei symmetrischer Motorgewichtsverteilung
* bei horizontaler und stationärer Einbaulage

(6) Die Angaben beziehen sich auf eine Abtriebswellendrehzahl von n₂=100 min⁻¹

(7) Bezogen auf die Mitte der Abtriebswelle

(8) Abweichende (teilweise höhere) Werte bei Änderungen von T_{2N}, F_r, F_a, sowie Zyklus und Lagerlebensdauer. Applikationsspezifische Auslegung mit NCP – www.neugart.com

(1) Number of stages

(2) The ratio-dependent values can be retrieved in Tec Data Finder – www.neugart.com

(3) T_{min} = -40°C. Optimal operating temperature max. 50°C

(4) Sound pressure level from 1 m, measured on input running at n₁=3000 rpm no load; i=5

(5) Max. motor weight* in kg = 0.2 x M_o / motor length in m
* with symmetrically distributed motor weight
* with horizontal and stationary mounting

(6) These values are based on an output shaft speed of n₂=100 rpm

(7) Based on center of output shaft

(8) Other (sometimes higher) values following changes to T_{2N}, F_r, F_a, cycle, and service life of bearing. Application specific configuration with NCP – www.neugart.com

Abtriebsdrehmomente	Output torques			PLN070	PLN090	PLN115	PLN142	PLN190	i ⁽¹⁾	p ⁽²⁾
Nenn-Abtriebsdrehmoment ⁽³⁾⁽⁴⁾	Nominal output torque ⁽³⁾⁽⁴⁾	T _{2N}	Nm	45	100	230	450	1000	3	1
				60	140	300	600	1300	4	
				65	140	260	750	1600	5	
				45	90	180	530	1300	7	
				40	80	150	450	1000	8	
				27	60	125	305	630	10	
				68	110	250	780	1500	12	2
				68	110	250	780	1500	15	
				77	150	300	1000	1800	16	
				77	150	300	1000	1800	20	
				65	140	260	900	1800	25	
				77	150	300	1000	1800	32	
				65	140	260	900	1800	40	
				40	80	150	450	1000	64	
27	60	125	305	630	100					
Max. Abtriebsdrehmoment ⁽⁴⁾⁽⁵⁾	Max. output torque ⁽⁴⁾⁽⁵⁾	T _{2max}	Nm	72	160	368	720	1600	3	1
				96	224	480	960	2080	4	
				104	224	416	1200	2560	5	
				72	144	288	848	2080	7	
				64	128	240	720	1600	8	
				43	96	200	488	1008	10	
				109	176	400	1248	2400	12	2
				109	176	400	1248	2400	15	
				123	240	480	1600	2880	16	
				123	240	480	1600	2880	20	
				104	224	416	1440	2880	25	
				123	240	480	1600	2880	32	
				104	224	416	1440	2880	40	
				64	128	240	720	1600	64	
43	96	200	488	1008	100					

⁽¹⁾ Übersetzungen (i=n₁/n₂)

⁽²⁾ Anzahl Getriebestufen

⁽³⁾ Applikationsspezifische Auslegung mit NCP – www.neugart.com

⁽⁴⁾ Werte bei Passfeder (Code „A“): für schwelende Belastung

⁽⁵⁾ Zulässig für 30.000 Umdrehungen der Abtriebswelle; siehe Seite 158

⁽¹⁾ Ratios (i=n₁/n₂)

⁽²⁾ Number of stages

⁽³⁾ Application specific configuration with NCP – www.neugart.com

⁽⁴⁾ Values for feather key (code "A"): for repeated load

⁽⁵⁾ 30,000 rotations of the output shaft permitted; see page 159

Abtriebsdrehmomente	Output torques			PLN070	PLN090	PLN115	PLN142	PLN190	i ⁽¹⁾	p ⁽²⁾		
Not-Aus Drehmoment ⁽³⁾	Emergency stop torque ⁽³⁾	T _{2Stop}	Nm	90	210	490	975	2000	3	1		
				120	280	650	1300	2700	4			
				130	280	650	1500	3200	5			
				80	175	340	1300	2600	7			
				90	200	380	1000	2600	8			
				90	200	480	750	1350	10			
				135	220	500	1500	3000	12			
				135	220	500	1500	3000	15			
						150	300	650	2000	3600	16	2
						150	300	650	2000	3600	20	
						150	300	650	1800	3600	25	
						150	300	650	2000	3600	32	
						150	300	650	1800	3600	40	
						80	200	380	1000	2600	64	
						80	200	480	750	1350	100	
						80	200	480	750	1350	100	

Antriebsdrehzahlen	Input speeds			PLN070	PLN090	PLN115	PLN142	PLN190	i ⁽¹⁾	p ⁽²⁾		
Mittlere thermische Antriebsdrehzahl bei T _{2N} und S1 ⁽⁴⁾⁽⁵⁾	Average thermal input speed at T _{2N} and S1 ⁽⁴⁾⁽⁵⁾	n _{1N}	min ⁻¹	2050 ⁽⁶⁾	1950 ⁽⁶⁾	1500 ⁽⁶⁾	850 ⁽⁶⁾	700 ⁽⁶⁾	3	1		
				2300 ⁽⁶⁾	2100 ⁽⁶⁾	1600 ⁽⁶⁾	950 ⁽⁶⁾	750 ⁽⁶⁾	4			
				2650 ⁽⁶⁾	2500 ⁽⁶⁾	2000 ⁽⁶⁾	1050 ⁽⁶⁾	850 ⁽⁶⁾	5			
				3450 ⁽⁶⁾	3550 ⁽⁶⁾	2800 ⁽⁶⁾	1550 ⁽⁶⁾	1200 ⁽⁶⁾	7			
				3800 ⁽⁶⁾	3950 ⁽⁶⁾	3200 ⁽⁶⁾	1800 ⁽⁶⁾	1450 ⁽⁶⁾	8			
				4400 ⁽⁶⁾	4000	3500 ⁽⁶⁾	2250 ⁽⁶⁾	1900 ⁽⁶⁾	10			
				3550 ⁽⁶⁾	3400 ⁽⁶⁾	2450 ⁽⁶⁾	1300 ⁽⁶⁾	1000 ⁽⁶⁾	12			
				4000 ⁽⁶⁾	4000 ⁽⁶⁾	3000 ⁽⁶⁾	1600 ⁽⁶⁾	1250 ⁽⁶⁾	15			
						3800 ⁽⁶⁾	3550 ⁽⁶⁾	2550 ⁽⁶⁾	1350 ⁽⁶⁾	1050 ⁽⁶⁾	16	2
						4300 ⁽⁶⁾	4000 ⁽⁶⁾	3050 ⁽⁶⁾	1600 ⁽⁶⁾	1300 ⁽⁶⁾	20	
						4500 ⁽⁶⁾	4000 ⁽⁶⁾	3400 ⁽⁶⁾	1850 ⁽⁶⁾	1400 ⁽⁶⁾	25	
						4500	4000	3500 ⁽⁶⁾	2300 ⁽⁶⁾	1900 ⁽⁶⁾	32	
						4500	4000	3500	2550 ⁽⁶⁾	2100 ⁽⁶⁾	40	
						4500	4000	3500	3000 ⁽⁶⁾	2500 ⁽⁶⁾	64	
						4500	4000	3500	3000	2500	100	
						4500	4000	3500	3000	2500	100	
Max. mechanische Antriebsdrehzahl ⁽⁴⁾	Max. mechanical input speed ⁽⁴⁾	n _{1Limit}	min ⁻¹	14000	10000	8500	6500	6000				

⁽¹⁾ Übersetzungen (i=n₁/n₂)

⁽²⁾ Anzahl Getriebestufen

⁽³⁾ 1000-mal zulässig

⁽⁴⁾ Applikationsspezifische Auslegung der Drehzahlen mit NCP – www.neugart.com

⁽⁵⁾ Definition siehe Seite 158

⁽⁶⁾ Mittlere thermische Antriebsdrehzahl bei 50% T_{2N} und S1

⁽¹⁾ Ratios (i=n₁/n₂)

⁽²⁾ Number of stages

⁽³⁾ Permitted 1000 times

⁽⁴⁾ Application-specific speed configurations with NCP – www.neugart.com

⁽⁵⁾ See page 159 for the definition

⁽⁶⁾ Average thermal input speed at 50% T_{2N} and S1

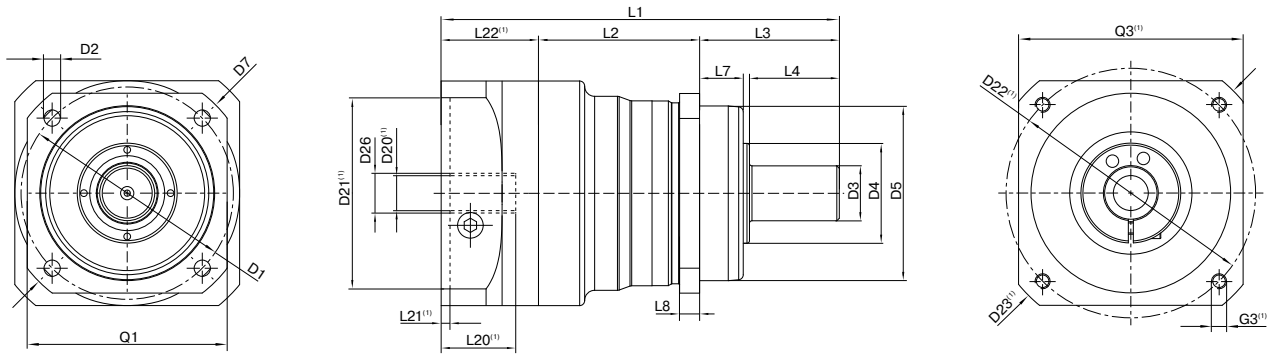

Darstellung entspricht einem PLN090 / 1-stufig / glatte Abtriebswelle / 19 mm Spannsystem / Motoranpassung – 2-teilig – runder Universalfansch / B5 Flanschttyp Motor
 Drawing corresponds to a PLN090 / 1-stage / smooth output shaft / 19 mm clamping system / motor adaptation – 2-part – round universal flange / B5 flange type motor

⁽¹⁾ Die Maße variieren je nach Motor-/Getriebeflansch. Die motorspezifischen Antriebsflansch-Geometrien können im Tec Data Finder für jeden Motor gezielt abgerufen werden - www.neugart.com
⁽¹⁾ The dimensions vary with the motor/gearbox flange. The input flange dimensions can be retrieved for each specific motor in Tec Data Finder at www.neugart.com

Geometrie ⁽²⁾	Geometry ⁽²⁾			PLN070	PLN090	PLN115	PLN142	PLN190	p ⁽³⁾	Code
Lochkreisdurchmesser Abtrieb	Pitch circle diameter output	D1		68 - 75	85	120	165	215		
Montagebohrung Abtrieb	Mounting bore output	D2	4x	5,5	6,5	9,0	11,0	13,5		
Wellendurchmesser Abtrieb	Shaft diameter output	D3	k6	16	22	32	40	55		
Wellenansatz Abtrieb	Shaft collar output	D4		35	40	45	70	80		
ZentrierbundØ Abtrieb	Centering Ø output	D5	g7	60	70	90	130	160		
Diagonalmass Abtrieb	Diagonal dimension output	D7		92	100	140	185	240		
Flanschquerschnitt Abtrieb	Flange cross section output	Q1	■	70	80	110	142	190		
Min. Gesamtlänge	Min. total length	L1		137,5	159,5	201	276	310,5	1	
				166,5	191,5	241	335	382,5	2	
Gehäuselänge	Housing length	L2		58,5	64,5	61	91,5	116	1	
				88	96,5	101,5	150,5	188	2	
Zentrierbundtiefe Abtrieb	Centering depth output	L7		19	17,5	28	28	28		
Flanschdicke Abtrieb	Flange thickness output	L8		7	8	10	12	15		
Durchmesser Motorwelle j6/k6	Motor shaft diameter j6/k6	D20		Weitere Informationen auf Seite 155/156 More information on page 155/156						
Ø Spannsystem am Antrieb	Clamping system Ø input	D26		Weitere Informationen auf Seite 155/156 More information on page 155/156						
Abtriebswelle mit Passfeder (DIN 6885-1)	Output shaft with feather key (DIN 6885-1)			A 5x5x25	A 6x6x28	A 10x8x50	A 12x8x65	A 16x10x70		
Passfederbreite (DIN 6885-1)	Feather key width (DIN 6885-1)	B1		5	6	10	12	16		
Wellenhöhe inklusive Passfeder (DIN 6885-1)	Shaft height including feather key (DIN 6885-1)	H1		18	24,5	35	43	59		
Wellenlänge Abtrieb	Shaft length output	L3		48	56	88	110	112		A
Wellenlänge bis Bund	Shaft length from shoulder	L4		28	36	58	80	82		
Passfederlänge	Feather key length	L5		25	28	50	65	70		
Abstand vom Wellenende	Distance from shaft end	L6		2	4	4	8	6		
Zentrierbohrung (DIN 332, Form DR)	Center hole (DIN 332, type DR)	C		M5x12,5	M8x19	M12x28	M16x36	M20x42		
Glatte Abtriebswelle	Smooth output shaft									
Wellenlänge Abtrieb	Shaft length output	L3		48	56	88	110	112		B
Wellenlänge bis Bund	Shaft length from shoulder	L4		28	36	58	80	82		
Verzahnnte Abtriebswelle (DIN 5480)	Splined output shaft (DIN 5480)			W16x0,8x18x6m	W22x1,25x16x6m	W32x1,25x24x6m	W40x2,0x18x6m	W55x2,0x26x6m		
Verzahnungsbreite	Width of gearing	L _v		15	15	15	20	22		
Wellenlänge Abtrieb	Shaft length output	L3		46	46	56	70	71,5		C
Wellenlänge bis Bund	Shaft length from shoulder	L4		26	26	26	40	41,5		
Zentrierbohrung (DIN 332, Form DR)	Center hole (DIN 332, type DR)	C		M5x12,5	M8x19	M12x28	M16x36	M20x42		

⁽²⁾ Maße in mm
⁽³⁾ Anzahl Getriebestufen

⁽²⁾ Dimensions in mm
⁽³⁾ Number of stages