

# WPLE

## Das vielseitige Winkel-Planetengetriebe mit geringem Gewicht und überzeugender Wirtschaftlichkeit

Das **WPLE** führt die Vorteile der Economy-Baureihe konsequent fort. Mit seiner kompakten aber kraftvollen Bauweise eignet es sich perfekt für dynamische Mehrachssysteme. Unser Winkelgetriebe ist lebensdauergeschmiert, einfach montierbar und das zu einem unerreichten Preis-Leistungs-Verhältnis.

## The versatile right angle planetary gearbox with lower weight and appealing cost effectiveness

The **WPLE** is a consistent continuation of the benefits offered by the Economy Line. With its compact, but powerful design, it is ideal for dynamic multiple axis systems. Our right angle gearbox features lifetime lubrication, is easy to install, all this at an unrivalled price-performance ratio.

Nenn-Abtriebsdrehmoment  
Nominal output torque **5 - 260 Nm**

Radialkraft  
Radial force **200 - 1750 N**

Axialkraft  
Axial force **200 - 2500 N**

Verdrehspiel  
Torsional backlash **11 - 28 arcmin**

Schutzart  
Protection class **IP54**

Baugrößen  
Frame sizes



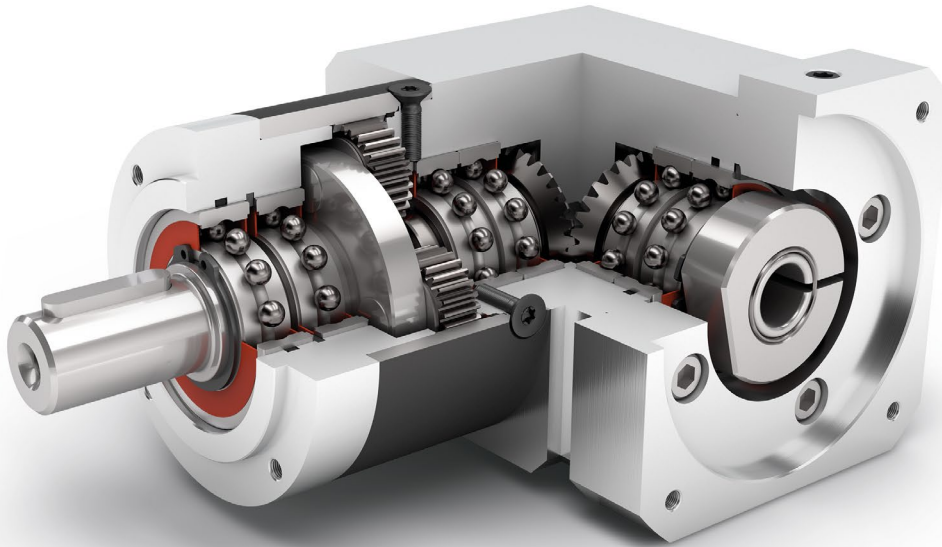

Economy Line  
Economy Line



Winkelgetriebe  
Right angle gearbox



Geradverzahnt  
Spur gear

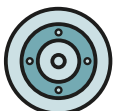

Runder Abtriebsflansch  
Round type output flange



Hohe Übersetzungsvielfalt  $i=3$  bis  $i=512$   
High ratio variety  $i=3$  up to  $i=512$

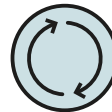

Drehrichtung gleichsinnig  
Equidirectional rotation



Kegelradwinkelstufe  
Bevel gear right angle stage



Reibungsarme Rillenkugellager  
Low-friction deep groove ball bearings



Planetenträger in Scheibenausführung  
Planet carrier in disc design

Detaillierte Erläuterungen der technischen Features ab Seite 169.  
Detailed explanations of the technical features starting on page 169.

Code	Getriebekennwerte	Gearbox characteristics			WPLE040	WPLE060	WPLE080	WPLE120	p <sup>(1)</sup>
	Lebensdauer (L <sub>10h</sub> )	Service life (L <sub>10h</sub> )	t <sub>L</sub>	h	20.000				
	Lebensdauer bei T <sub>2N</sub> x 0,88	Service life at T <sub>2N</sub> x 0,88			30.000				
	Wirkungsgrad bei Vollast <sup>(2)</sup>	Efficiency at full load <sup>(2)</sup>	η	%	95				1
					94				2
					88				3
	Betriebstemperatur min.	Min. operating temperature	T <sub>min</sub>	°C	-25				
	Betriebstemperatur max.	Max. operating temperature	T <sub>max</sub>		90				
	Schutzart	Protection class			IP54				
S	Standard Schmierung	Standard lubrication			Fett (lebensdauergeschmiert) / Grease (lifetime lubrication)				
F	Lebensmitteltaugliche Schmierung	Food grade lubrication			Fett (lebensdauergeschmiert) / Grease (lifetime lubrication)				
L	Tieftemperatur Schmierung <sup>(3)</sup>	Low temperature lubrication <sup>(3)</sup>			Fett (lebensdauergeschmiert) / Grease (lifetime lubrication)				
	Einbaulage	Installation position			Beliebig / Any				
S	Standard Verdrehspiel	Standard backlash	j <sub>t</sub>	arcmin	< 21	< 16	< 13	< 11	1
					< 25	< 18	< 15	< 13	2
					< 28	< 21	< 17	< 15	3
	Verdrehsteifigkeit <sup>(2)</sup>	Torsional stiffness <sup>(2)</sup>	c <sub>G</sub>	Nm / arcmin	0,5 - 0,8	1,5 - 2,3	4,0 - 7,9	9,9 - 17,5	1
					0,7 - 1,0	2,2 - 2,7	6,9 - 9,6	16,4 - 20,5	2
					0,8 - 1,0	2,3 - 2,8	7,9 - 10,4	17,5 - 22,0	3
	Getriebegewicht <sup>(2)</sup>	Gearbox weight <sup>(2)</sup>	m <sub>G</sub>	kg	0,6	1,6	3,7	9,6 - 9,8	1
					0,7	1,8	4,1 - 4,2	11,4 - 11,6	2
					0,7 - 0,8	2,0	4,6 - 4,7	13,2 - 13,4	3
S	Standard Oberfläche	Standard surface			Gehäuse: Stahl – wärmebehandelt und nachoxidiert (schwarz) Housing: Steel – heat-treated and post-oxidized (black)				
	Laufgeräusch <sup>(4)</sup>	Running noise <sup>(4)</sup>	Q <sub>G</sub>	dB(A)	68	70	73	75	
	Max. Biegemoment bezogen auf den Getriebeantriebsflansch <sup>(5)</sup>	Max. bending moment based on the gearbox input flange <sup>(5)</sup>	M <sub>b</sub>	Nm	2	5	10,5	26	

Abtriebswellenbelastungen	Output shaft loads			WPLE040	WPLE060	WPLE080	WPLE120	p <sup>(1)</sup>
Radialkraft für 20.000 h <sup>(6)(7)</sup>	Radial force for 20,000 h <sup>(6)(7)</sup>	F <sub>r20.000h</sub>	N	200	400	750	1750	
Axialkraft für 20.000 h <sup>(6)(7)</sup>	Axial force for 20,000 h <sup>(6)(7)</sup>	F <sub>a20.000h</sub>		200	500	1000	2500	
Radialkraft für 30.000 h <sup>(6)(7)</sup>	Radial force for 30,000 h <sup>(6)(7)</sup>	F <sub>r30.000h</sub>		160	340	650	1500	
Axialkraft für 30.000 h <sup>(6)(7)</sup>	Axial force for 30,000 h <sup>(6)(7)</sup>	F <sub>a30.000h</sub>		160	450	900	2100	
Maximale Radialkraft <sup>(7)(8)</sup>	Maximum radial force <sup>(7)(8)</sup>	F <sub>r Stat</sub>		200	700	1250	2000	
Maximale Axialkraft <sup>(7)(8)</sup>	Maximum axial force <sup>(7)(8)</sup>	F <sub>a Stat</sub>		240	800	1600	3800	
Kippmoment für 20.000 h <sup>(6)(8)</sup>	Tilting moment for 20,000 h <sup>(6)(8)</sup>	M <sub>K20.000h</sub>	Nm	5	14	31	101	
Kippmoment für 30.000 h <sup>(6)(8)</sup>	Tilting moment for 30,000 h <sup>(6)(8)</sup>	M <sub>K30.000h</sub>		4	12	27	86	

Trägheitsmoment	Moment of inertia			WPLE040	WPLE060	WPLE080	WPLE120	p <sup>(1)</sup>
Massenträgheitsmoment <sup>(2)</sup>	Mass moment of inertia <sup>(2)</sup>	J	kgcm <sup>2</sup>	0,032 - 0,049	0,221 - 0,357	0,910 - 1,273	1,820 - 2,846	1
				0,032 - 0,048	0,222 - 0,350	0,916 - 1,232	1,855 - 2,773	2
				0,032 - 0,047	0,222 - 0,232	0,916 - 1,209	1,854 - 2,681	3

(1) Anzahl Getriebestufen

(2) Die übersetzungsabhängigen Werte sind im Tec Data Finder abrufbar – [www.neugart.com](http://www.neugart.com)

(3) T<sub>min</sub> = -40°C. Optimale Betriebstemperatur max. 50°C

(4) Schalldruckpegel in 1 m Abstand; gemessen bei einer Antriebsdrehzahl von n<sub>1</sub>=3000 min<sup>-1</sup> ohne Last; i=5

(5) Max. Motorgewicht\* in kg = 0,2 x M<sub>o</sub> / Motorlänge in m  
\* bei symmetrischer Motorgewichtsverteilung  
\* bei horizontaler und stationärer Einbaulage

(6) Die Angaben beziehen sich auf eine Abtriebswellendrehzahl von n<sub>2</sub>=100 min<sup>-1</sup>

(7) Bezogen auf die Mitte der Abtriebswelle

(8) Abweichende (teilweise höhere) Werte bei Änderungen von T<sub>2N</sub>, F<sub>r</sub>, F<sub>a</sub>, sowie Zyklus und Lagerlebensdauer. Applikationsspezifische Auslegung mit NCP – [www.neugart.com](http://www.neugart.com)

(1) Number of stages

(2) The ratio-dependent values can be retrieved in Tec Data Finder – [www.neugart.com](http://www.neugart.com)

(3) T<sub>min</sub> = -40°C. Optimal operating temperature max. 50°C

(4) Sound pressure level from 1 m, measured on input running at n<sub>1</sub>=3000 rpm no load; i=5

(5) Max. motor weight\* in kg = 0.2 x M<sub>o</sub> / motor length in m  
\* with symmetrically distributed motor weight  
\* with horizontal and stationary mounting

(6) These values are based on an output shaft speed of n<sub>2</sub>=100 rpm

(7) Based on center of output shaft

(8) Other (sometimes higher) values following changes to T<sub>2N</sub>, F<sub>r</sub>, F<sub>a</sub>, cycle, and service life of bearing. Application specific configuration with NCP – [www.neugart.com](http://www.neugart.com)

Abtriebsdrehmomente	Output torques			WPLE040	WPLE060	WPLE080	WPLE120	i <sup>(1)</sup>	p <sup>(2)</sup>
Nenn-Abtriebsdrehmoment <sup>(3)(4)</sup>	Nominal output torque <sup>(3)(4)</sup>	T <sub>2N</sub>	Nm	4,5	14	40 <sup>(5)</sup>	80 <sup>(5)</sup>	3	1
				6	19	53 <sup>(5)</sup>	105 <sup>(5)</sup>	4	
				7,5	24	67 <sup>(5)</sup>	130 <sup>(5)</sup>	5	
				8,5	25	65	135	7	
				6	18	50	120	8	
				5	15	38	95	10	2
				16,5 <sup>(5)</sup>	44 <sup>(5)</sup>	130 <sup>(5)</sup>	210 <sup>(5)</sup>	9	
				20 <sup>(5)</sup>	44	120 <sup>(5)</sup>	260 <sup>(5)</sup>	12	
				18 <sup>(5)</sup>	44	110	230	15	
				20 <sup>(5)</sup>	44	120	260	16	
				20 <sup>(5)</sup>	44	120	260	20	
				18	40	110	230	25	
				20	44	120	260	32	
				18	40	110	230	40	
				7,5	18	50	120	64	
				20	44	110	260	60	
				20	44	120	260	80	
				20	44	120	260	100	
				18	44	110	230	120	
				20	44	120	260	160	
18	40	110	230	200					
20	44	120	260	256					
18	40	110	230	320					
7,5	18	50	120	512					
Max. Abtriebsdrehmoment <sup>(4)(6)</sup>	Max. output torque <sup>(4)(6)</sup>	T <sub>2max</sub>	Nm	7	22	64	128	3	1
				10	30	85	168	4	
				12	38	107	208	5	
				13,5	40	104	216	7	
				10	29	80	192	8	
				8	24	61	152	10	2
				26	70	208	336	9	
				32	70	192	416	12	
				29	70	176	368	15	
				32	70	192	416	16	
				32	70	192	416	20	
				29	64	176	368	25	
				32	70	192	416	32	
				29	64	176	368	40	
				12	29	80	192	64	
				32	70	176	416	60	
				32	70	192	416	80	
				32	70	192	416	100	
				29	70	176	368	120	
				32	70	192	416	160	
29	64	176	368	200					
32	70	192	416	256					
29	64	176	368	320					
12	29	80	192	512					

WPLE

(1) Übersetzungen (i=n<sub>1</sub>/n<sub>2</sub>)  
 (2) Anzahl Getriebestufen  
 (3) Applikationsspezifische Auslegung mit NCP – www.neugart.com  
 (4) Werte bei Passfeder (Code „A“): für schwelende Belastung  
 (5) Lebensdauer abweichend: 10.000 h bei T<sub>2N</sub>  
 (6) Zulässig für 30.000 Umdrehungen der Abtriebswelle; siehe Seite 158

(1) Ratios (i=n<sub>1</sub>/n<sub>2</sub>)  
 (2) Number of stages  
 (3) Application specific configuration with NCP – www.neugart.com  
 (4) Values for feather key (code "A"): for repeated load  
 (5) Different service life: 10,000 h at T<sub>2N</sub>  
 (6) 30,000 rotations of the output shaft permitted; see page 159

WPLE

Abtriebsdrehmomente	Output torques			WPLE040	WPLE060	WPLE080	WPLE120	i <sup>(1)</sup>	p <sup>(2)</sup>
Not-Aus Drehmoment <sup>(3)</sup>	Emergency stop torque <sup>(3)</sup>	T <sub>2Stop</sub>	Nm	22,5	66	180	360	3	1
				28	86	240	474	4	
				35	80	220	500	5	
				26	80	178	340	7	
				27	80	190	380	8	
				25	70	170	430	10	
				33	88	260	500	9	2
				40	88	240	520	12	
				36	88	220	500	15	
				40	88	240	520	16	
				40	88	240	520	20	
				36	80	220	500	25	
				40	88	240	520	32	3
				36	80	220	500	40	
				27	80	190	380	64	
				40	88	220	520	60	
				40	88	240	520	80	
				40	88	240	520	100	
				36	88	220	500	120	3
				40	88	240	520	160	
36	80	220	500	200					
40	88	240	520	256					
36	80	220	500	320					
27	80	190	380	512					

Antriebsdrehzahlen	Input speeds			WPLE040	WPLE060	WPLE080	WPLE120	i <sup>(1)</sup>	p <sup>(2)</sup>
Mittlere thermische Antriebsdrehzahl bei T <sub>2N</sub> und S1 <sup>(4)(5)</sup>	Average thermal input speed at T <sub>2N</sub> and S1 <sup>(4)(5)</sup>	n <sub>1N</sub>	min <sup>-1</sup>	5000	4500 <sup>(6)</sup>	3500 <sup>(6)</sup>	2850 <sup>(6)</sup>	3	1
				5000	4500 <sup>(6)</sup>	3550 <sup>(6)</sup>	2950 <sup>(6)</sup>	4	
				5000	4500 <sup>(6)</sup>	3600 <sup>(6)</sup>	3050 <sup>(6)</sup>	5	
				5000	4500	4000 <sup>(6)</sup>	3500 <sup>(6)</sup>	7	
				5000	4500	4000 <sup>(6)</sup>	3500 <sup>(6)</sup>	8	
				5000	4500	4000	3500	10	
				5000	4500 <sup>(6)</sup>	3250 <sup>(6)</sup>	2950 <sup>(6)</sup>	9	2
				5000	4500 <sup>(6)</sup>	3850 <sup>(6)</sup>	3050 <sup>(6)</sup>	12	
				5000	4500	4000 <sup>(6)</sup>	3500 <sup>(6)</sup>	15	
				5000	4500	4000 <sup>(6)</sup>	3450 <sup>(6)</sup>	16	
				5000	4500	4000 <sup>(6)</sup>	3500 <sup>(6)</sup>	20	
				5000	4500	4000	3500 <sup>(6)</sup>	25	
				5000	4500	4000	3500	32	3
				5000	4500	4000	3500	40	
				5000	4500	4000	3500	64	
				5000	4500	4000	3500	60	
				5000	4500	4000	3500	80	
				5000	4500	4000	3500	100	
				5000	4500	4000	3500	120	3
				5000	4500	4000	3500	160	
5000	4500	4000	3500	200					
5000	4500	4000	3500	256					
5000	4500	4000	3500	320					
5000	4500	4000	3500	512					
Max. mechanische Antriebsdrehzahl <sup>(4)</sup>	Max. mechanical input speed <sup>(4)</sup>	n <sub>1Limit</sub>	min <sup>-1</sup>	18000	13000	7000	6500		

<sup>(1)</sup> Übersetzungen (i=n<sub>1</sub>/n<sub>2</sub>)

<sup>(2)</sup> Anzahl Getriebestufen

<sup>(3)</sup> 1000-mal zulässig

<sup>(4)</sup> Applikationsspezifische Auslegung der Drehzahlen mit NCP – www.neugart.com

<sup>(5)</sup> Definition siehe Seite 158

<sup>(6)</sup> Mittlere thermische Antriebsdrehzahl bei 50% T<sub>2N</sub> und S1

<sup>(1)</sup> Ratios (i=n<sub>1</sub>/n<sub>2</sub>)

<sup>(2)</sup> Number of stages

<sup>(3)</sup> Permitted 1000 times

<sup>(4)</sup> Application-specific speed configurations with NCP – www.neugart.com

<sup>(5)</sup> See page 159 for the definition

<sup>(6)</sup> Average thermal input speed at 50% T<sub>2N</sub> and S1

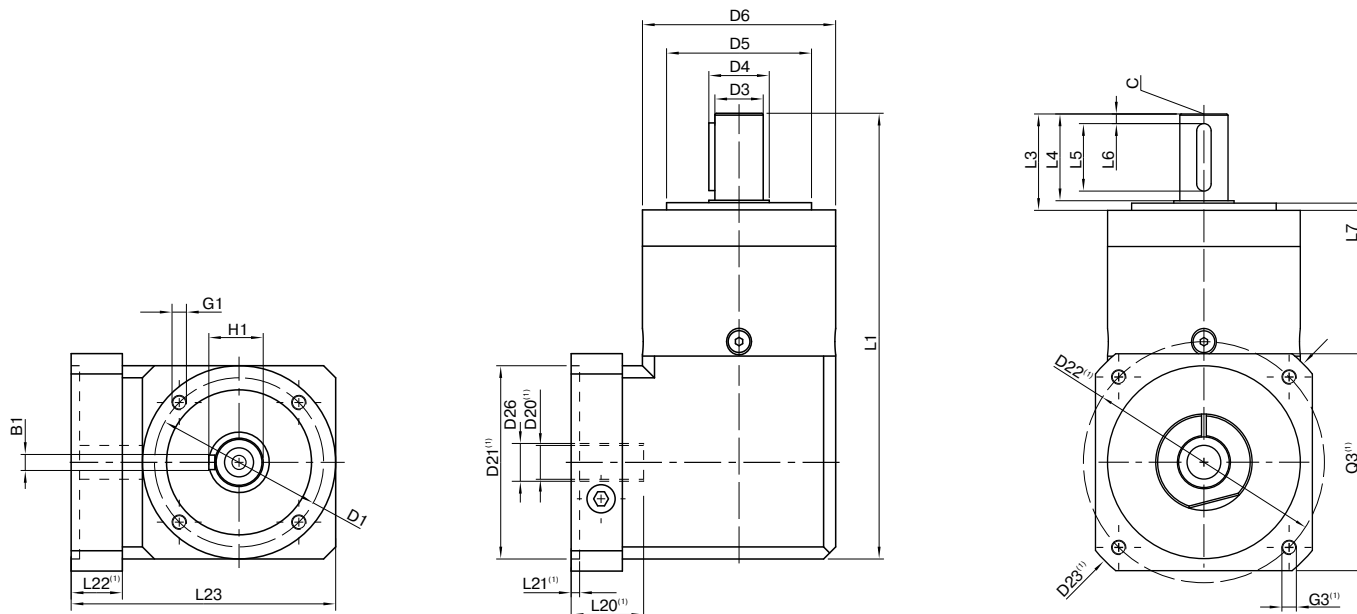

Darstellung entspricht einem WPLE080 / 1-stufig / Abtriebswelle mit Passfeder / 19 mm Spannsystem / Motoranpassung – 2-teilig – quadratischer Universalfansch / B5 Flanschttyp Motor  
 Drawing corresponds to a WPLE080 / 1-stage / output shaft with feather key / 19 mm clamping system / motor adaptation – 2-part – square universal flange / B5 flange type motor

<sup>(1)</sup> Die Maße variieren je nach Motor-/Getriebeflansch. Die motorspezifischen Antriebsflansch-Geometrien können im Tec Data Finder für jeden Motor gezielt abgerufen werden - www.neugart.com  
<sup>(1)</sup> The dimensions vary with the motor/gearbox flange. The input flange dimensions can be retrieved for each specific motor in Tec Data Finder at www.neugart.com

Geometrie <sup>(2)</sup>	Geometry <sup>(2)</sup>			WPLE040	WPLE060	WPLE080	WPLE120	p <sup>(3)</sup>	Code
Lochkreisdurchmesser Abtrieb	Pitch circle diameter output	D1		34	52	70	100		
Wellendurchmesser Abtrieb	Shaft diameter output	D3	h7	10	14	20	25		
Wellenansatz Abtrieb	Shaft collar output	D4		12	17	25	35		
ZentrierbundØ Abtrieb	Centering diameter output	D5	h7	26	40	60	80		
Gehäusedurchmesser	Housing diameter	D6		40	60	80	115		
Anschraubgewinde x Tiefe	Mounting thread x depth	G1	4x	M4x6	M5x8	M6x10	M10x16		
Gesamtlänge	Total length	L1		110	147	184	249,5	1	
				123	159,5	201,5	277	2	
				135,5	172	219	304,5	3	
Wellenlänge Abtrieb	Shaft length output	L3		26	35	40	55		
Zentrierbundtiefe Abtrieb	Centering depth output	L7		2	3	3	4		
Min. Gesamthöhe	Min. overall height	L23		62	85,5	109,5	145,5		
Durchmesser Motorwelle j6/k6	Motor shaft diameter j6/k6	D20		Weitere Informationen auf Seite 155/156 More information on page 155/156					
Ø Spannsystem am Antrieb	Clamping system Ø input	D26		Weitere Informationen auf Seite 155/156 More information on page 155/156					
Abtriebswelle mit Passfeder (DIN 6885-1)	Output shaft with feather key (DIN 6885-1)			A 3x3x18	A 5x5x25	A 6x6x28	A 8x7x40		A
Passfederbreite (DIN 6885-1)	Feather key width (DIN 6885-1)	B1		3	5	6	8		
Wellenhöhe inklusive Passfeder (DIN 6885-1)	Shaft height including feather key (DIN 6885-1)	H1		11,2	16	22,5	28		
Wellenlänge bis Bund	Shaft length from shoulder	L4		23	30	36	50		
Passfederlänge	Feather key length	L5		18	25	28	40		
Abstand vom Wellenende	Distance from shaft end	L6		2,5	2,5	4	5		
Zentrierbohrung (DIN 332, Form DR)	Center hole (DIN 332, type DR)	C		M3x9	M5x12,5	M6x16	M10x22		
Glatte Abtriebswelle	Smooth output shaft								B
Wellenlänge bis Bund	Shaft length from shoulder	L4		23	30	36	50		

<sup>(2)</sup> Maße in mm  
<sup>(3)</sup> Anzahl Getriebestufen

<sup>(2)</sup> Dimensions in mm  
<sup>(3)</sup> Number of stages