

LCMOS Grunddaten

LCMOS ist eine luxuriöse USB2.0-CMOS-Kamera mit Frame-Puffern, die einen hochleistungsfähigen CMOS-Sensor als Bildaufnahmegerät verwendet und USB 2.0 als Datenübertragungsschnittstelle verwendet. LCMOS wird mit der fortschrittlichen Video- und Bildverarbeitungsanwendung ToupView geliefert. Bereitstellung des SDK für mehrere Windows / Linux / OSX-Plattformen; Native C / C ++ -, C # / VB.NET-, DirectShow-, Twain Control-API; Der LCMOS kann in Hellfeldumgebungen und bei der Erfassung und Analyse von Mikroskopbildern eingesetzt werden.

Die Grundcharakteristika der LCMOS Kameras sind:

- Die C-Mount-Kamera mit Anschluss-Durchmesser von 25,4 mm oder 1 Zoll
- Kamera für wissenschaftliche Forschung mit Aptina CMOS-Sensor;
- Mit einer Hardware-Auflösung von 1,2 bis 14 M;
- Integrierter Speicher für perfekte Synchronisation, höhere Bildrate und stabile Leistung;
- Hochleistungskühlstruktur, sorgt für geringes Bildrauschen;
- USB 2.0, für hohe Bildrate;
- Ultra-Fine™-Farbmodul mit perfekter Farbwiedergabe;
- Inkl. der fortschrittlichen Video- und Bildverarbeitungsanwendung ToupView;
- Bereitstellung des SDK für mehrere Windows / Linux / Mac OS-Plattformen;
- Native API für C / C ++, C # / VB.NET, DirectShow und Twain Control;



Abmessungen

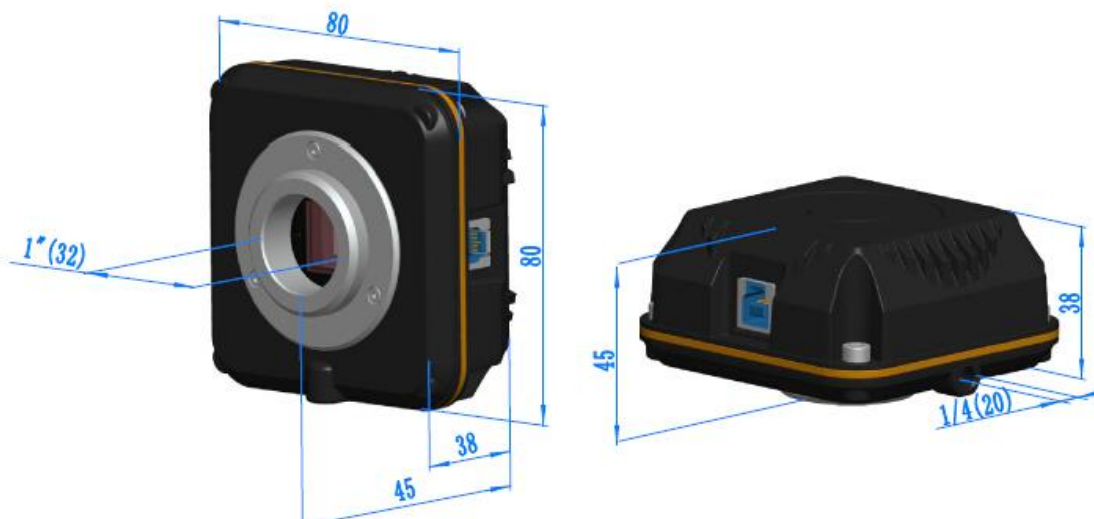

Lieferbare Versionen:

Order Code	Sensor & Size(mm)	Pixel(μm)	G Sensitivity Dark Signal	FPS/Resolution	Binning	Exposure
LCMOS14000KPA LP614000A	14M/MT9F002(C) 1/2.3"(5.73x4.60)	1.4x1.4	0.724v/lux-sec 65.3dB 35.5dB	2.7@4096x3288 10@2048x1644 35@1024x822	1x1, 2x2, 4x4	0.4ms~2000ms
LCMOS10000KPA LP610000A	10M/MT9J003(C) 1/2.3"(5.98x4.59)	1.67x1.67	0.31v/lux-sec 65.2dB 34dB	3.7@3584x2748 13@1792x1374 35@896x684	1x1, 2x2, 4x4	0.4ms~2000ms
LCMOS09000KPB LP609000B	9.0M/Special(C) 1/2.4"(5.83x4.37)	1.67x1.67	0.31v/lux-sec 65.2dB 34dB	3.9@3488x2616 15@1744x1308 47@872x654	1x1, 2x2, 4x4	0.4ms~2000ms
LCMOS08000KPB LP608000B	8.0M/Special(C) 1/2.5"(5.45x4.09)	1.67x1.67	0.31v/lux-sec 65.2dB 34dB	4.4@3264x2448 17@1600x1200 55@800x600	1x1, 2x2, 4x4	0.4ms~2000ms
LCMOS05100KPA LP605100A	5.1M/MT9P001(C) 1/2.5"(5.70x4.28)	2.2x2.2	0.53 V/lux-sec 66.5dB 40.5dB	6.8@2592x1944 18@1280x960 60@640x480	1x1, 2x2, 4x4	0.294ms~2000ms
LCMOS03100KPA LP603100A	3.1M/MT9T001(C) 1/2"(6.55x4.92)	3.2x3.2	1.0 V/lux-sec 61dB 43dB	11.5@2048x1536 32@1024x768 45@680x510	1x1, 2x2, 3x3	0.244ms~2000ms
LCMOS03100KPB LP603100B	IMX036(C) 1/2.8"(5.12x3.84)	2.5x2.5	200mv with 1/30s 0.5mv with 1/30s	12@2048x1536 48@1024x768 48@680x510	1x1, 2x2, 3x3	0.244ms~2000ms
LCMOS02000KPB LP602000B	2.0M/Special(C) 1/2.6"(5.12x3.84)	3.2x3.2	1.0 V/lux-sec 61dB 43dB	16@1600x1200 40@800x600	1x1, 2x2	0.244ms~2000ms
LCMOS01300KPA LP601300A	1.2M/MT9M111(C) 1/3"(4.60x3.70)	3.6x3.6	1.0 V/lux-sec 61dB 43dB	15@1280x1024 26@640x512 48@320x256	1x1, 2x2, 4x4	0.14ms~2000ms
LCMOS01200KPB LP601200B	1.2M/AR0130(C) 1/3" (4.80x3.60)	3.6x3.6	5.5v/lux-sec 85.3dB 44dB	28@1280x960 30@640x480	1x1, 2x2	0.14ms~2000ms
Spectral Range	380-650nm (with IR-filter), for Monochromatic Camera, AR Is Used					
White Balance	ROI White Balance/ Manual Temp-Tint Adjustment					
Color Rendering Technique	Ultra Fine Color Engine					
Capture/Control SDK	Windows/Linux/macOS/Android Multiple Platform SDK(Native C/C++, C#/VB.NET, Python, Java, DirectShow, Twain, etc);					
Recording System	Still Picture and Movie					
Cooling System*	Natural					
OPERATING ENVIRONMENT						
Operating Temperature	-10 °C~ 50 °C					
Storage Temperature	-20 °C~ 60 °C					
Operating Humidity	30~80%RH					
Storage Humidity	10~60%RH					
Power Supply	DC 5V over PC USB Port					
SOFTWARE ENVIRONMENT						
Operating System	Support Microsoft Windows XP / Vista / 7 / 8 / 10(32 & 64 bit) OS X (Mac OS X), Linux					
PC Requirements	CPU: Equal to Intel Core2 2.8GHz or Higher					
	Memory: 2GB or More					
	USB port: USB2.0 High-speed Port					
	Display: 17" or Larger					
	CD-ROM					

Lieferumfang



Standard Camera Packing List

A	Carton L:40cm W:36cm H:36cm (16pcs, 12~17Kg/ carton), not shown in the photo
B	Gift box L:16.4cm W:16.4cm H:7.5cm (0.7~0.8Kg/ box)
C	LCMOS series USB2.0 C-mount CMOS camera
D	High-speed USB2.0 A male to B male gold-plated connectors cable /2.0m
E	CD (Driver & utilities software, Ø12cm)

Optional Accessory

F	Adjustable lens adapter	C-mount to Dia.23.2mm eyepiece tube (Please choose 1 of them for your microscope)	108001/AMA037 108002/AMA050 108003/AMA075
		C-mount to Dia.31.75mm eyepiece tube (Please choose 1 of them for your telescope)	108008/ATA037 108009/ATA050 108010/ATA075
G	Fixed lens adaptor	C-mount to Dia.23.2mm eyepiece tube (Please choose 1 of them for your microscope)	108005/FMA037 108006/FMA050 108007/FMA075
		C-mount to Dia.31.75mm eyepiece tube (Please choose 1 of them for your telescope)	108011/FTA037 108012/FTA050 108013/FTA075
<p>Note: For F and G optional items, please specify your camera type(C-mount, microscope camera or telescope camera) , ToupTek engineer will help you to determine the right microscope or telescope camera adapter for your application;</p>			
H	108015(Dia.23.2mm to 30.0mm Ring)/Adaptor rings for 30mm eyepiece tube		
I	108016(Dia.23.2mm to 30.5mm Ring)/ Adaptor rings for 30.5mm eyepiece tube		
J	108017(Dia.23.2mm to 31.75mm Ring)/ Adaptor rings for 31.75mm eyepiece tube		
K	Calibration Lit	106011/TS-M1(X=0.01mm/100Div.);	
		106012/TS-M2(X,Y=0.01mm/100Div.);	
		106013/TS-M7(X=0.01mm/100Div., 0.10mm/100Div.)	

Optionale Adapter

Microscope Camera	 <p>LCMOS+AMAXXX(23.2mm Adapter)</p>	 <p>LCMOS+FMAXXX(23.2mm Adapter)</p>
Telescope Camera	 <p>LCMOS+ATAXXX(31.75mm Adapter)</p>	 <p>LCMOS+FTAXXX(31.75mm Adapter)</p>

Sample Images 1 Captured with L3CMOS Camera(L3CMOS14000KPA)

The microscope slide images are captured with TPS004025 slide package and with L3CMOS14000KPA camera.



1. Housefly Wing W.M.

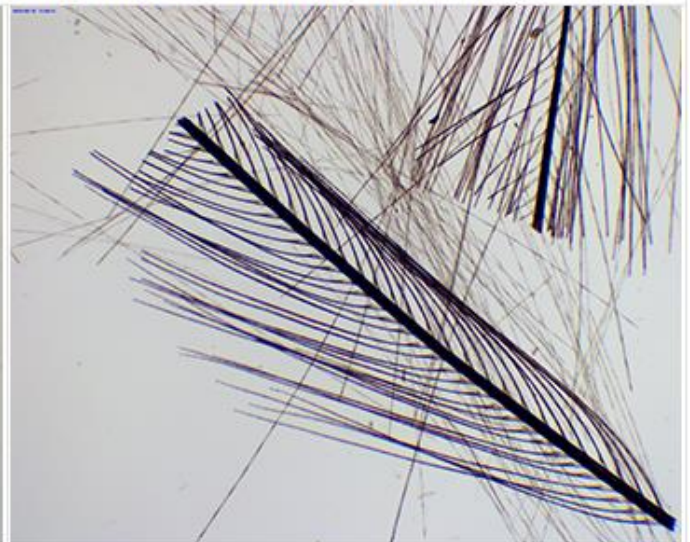

2. Bird Feather W.M.

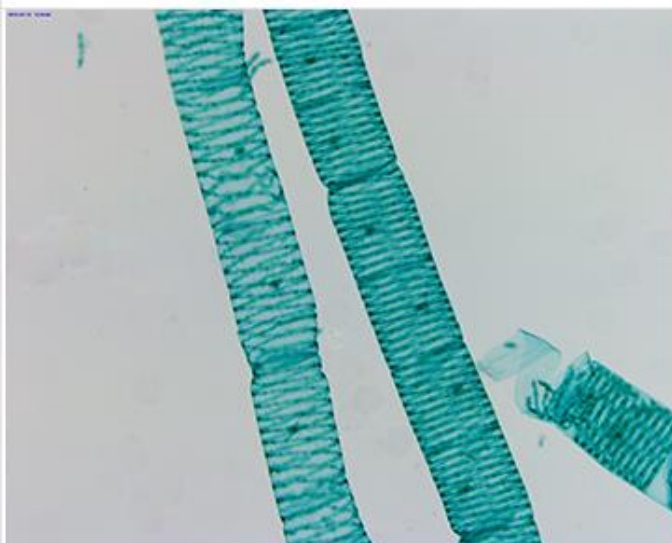

3. Spirogyra W.M.

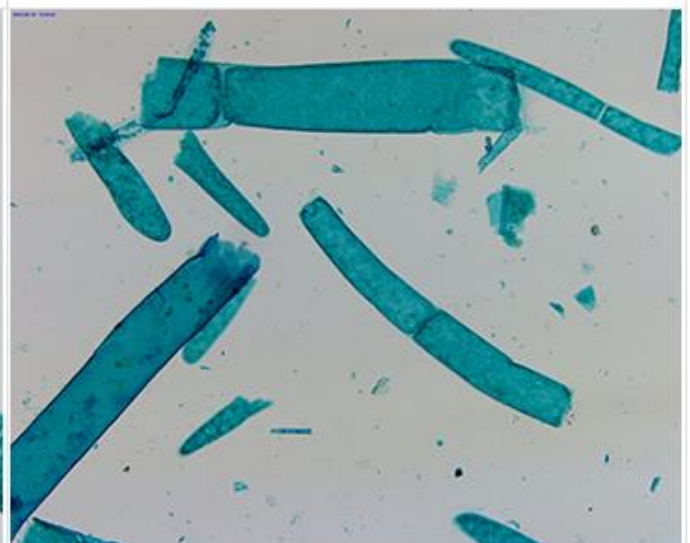

4. Moss Protonema W.M.

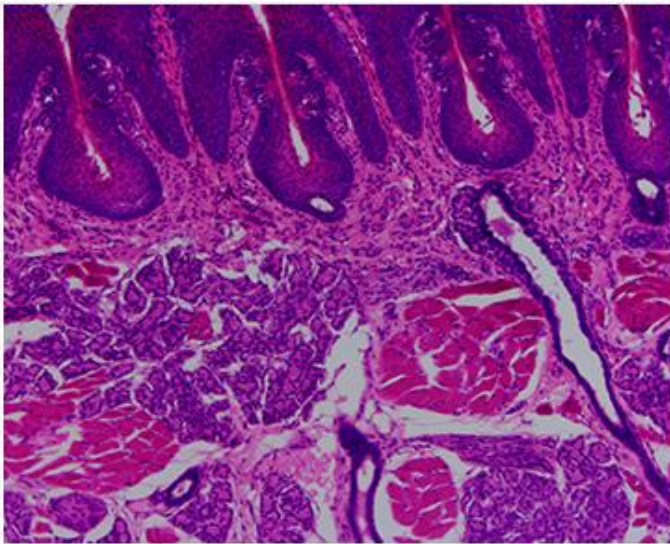

15. Taste Bud Sec(Rabbit)

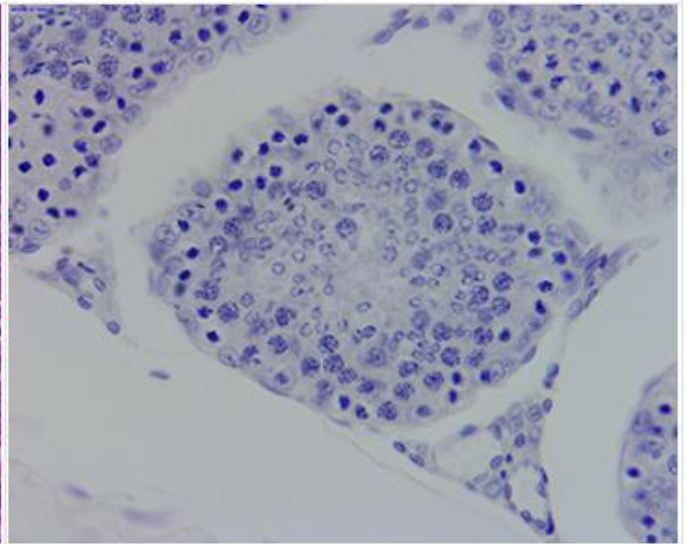

16. Spermery Sec

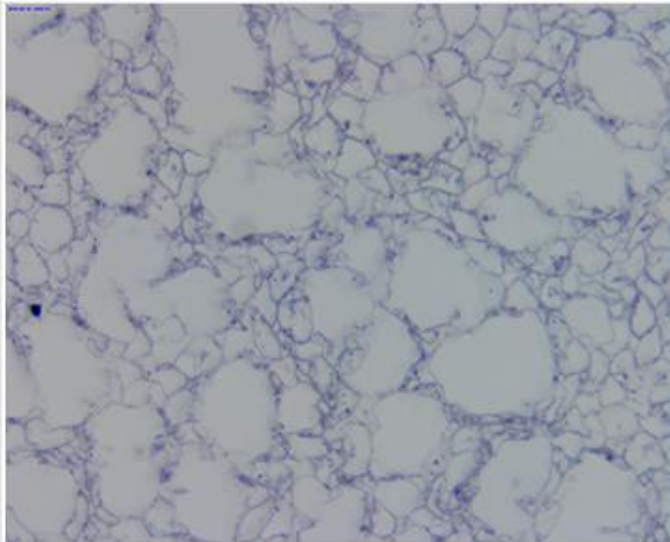

17. Umbrella Mushroom Sec



18. Honey Bee Third Pair of Legs W.M.

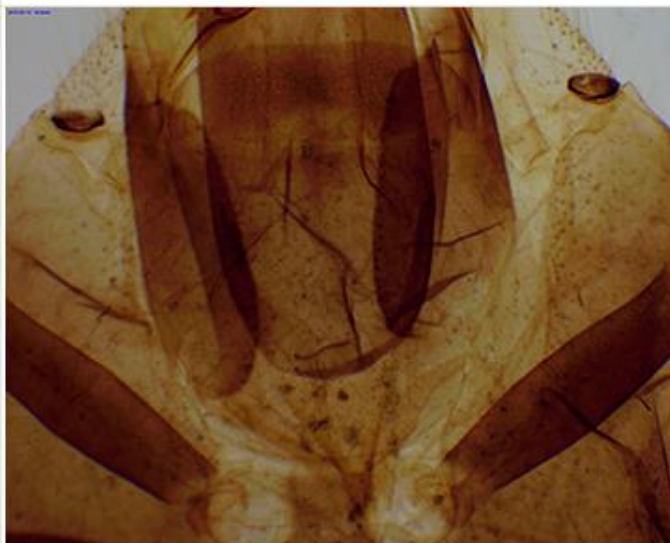

19. Honey Bee Mouth Parts W.M.

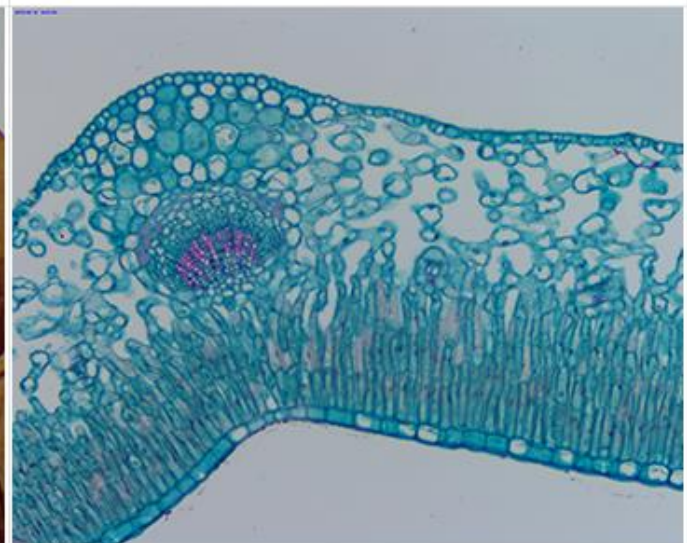

20. Winter Jasmine Leaf W.M.

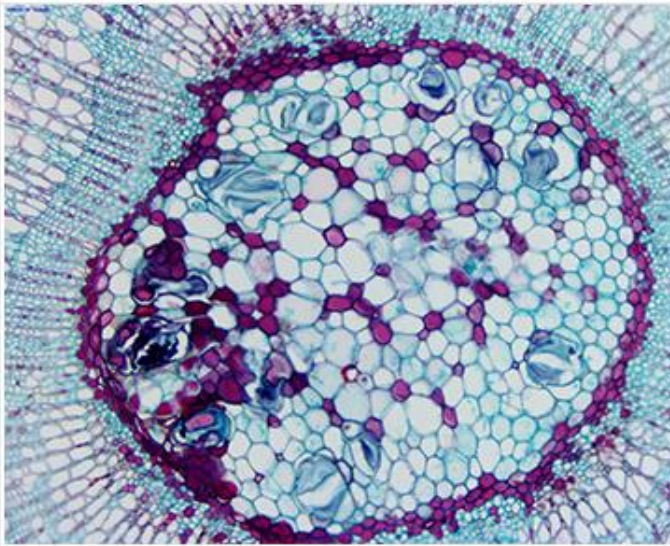

21. Stem to Show Annual Rings C.S.

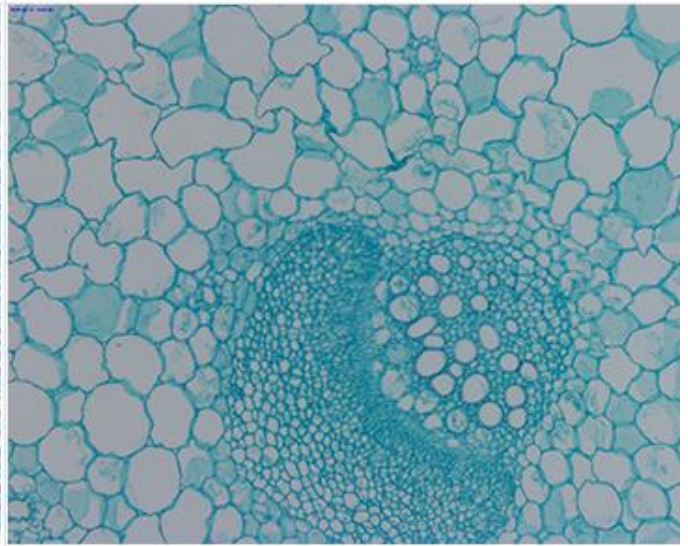

22. Collenchyma