

# BANDSCHLEIFAGGREGAT – CLASSIC LINE COLLEVO

## TECHNISCHE DATEN

Schmierung	Fett
max. Abtriebsdrehzahl $n_2$	2.700 min <sup>-1</sup>
Übersetzung ( $n_1: n_2$ )	1:0,9
Gewicht	ca. 9 kg

## STANDARDAUSFÜHRUNG

- 1  Maschinenanbindung  
HSK - F63
- 2  Schleifband  
Breite 100 mm, Länge 560 mm

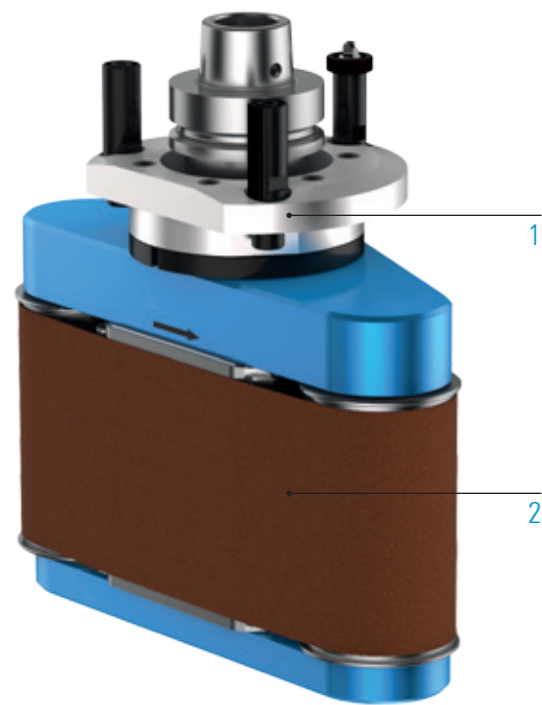

## WEITERE OPTIONEN: MODULARER AUFBAU

1



### MASCHINENANBINDUNG



 Weitere Informationen S. 106

2



### SCHLEIFBAND







## BEARBEITUNG



Schleifen

## SPEZIFIKATIONEN

-  Anzahl  
Werkzeugaufnahmen
-  Achswinkel
-  C-Winkel
-  Fettschmierung

## VIDEO



Aggregat – live in der Anwendung  
QR Code scannen oder alternativ:  
[www.youtube.com/BENZWerkzeugsysteme](http://www.youtube.com/BENZWerkzeugsysteme)

## DIREKT BESTELLEN



Anfrageformular:  
[www.benz-tools.de/de/produkte](http://www.benz-tools.de/de/produkte)