



Advantages:

- ✓ With thread- and flange connection
- ✓ Single- and double acting
- ✓ Simple installation and mounting
- ✓ Mounting position independent
- ✓ With optional metal scraper
- ✓ With optional throttling



General

Description:

These swing clamps are pull cylinders in which by pressurization on the piston rod side, the rotational movement of the piston is generated (swing stroke). After the pivoting movement is completed, the actual clamping stroke is initiated. Swivel and clamping stroke result in the total stroke.

The swing clamps are offered as a superstructure version and can be operated by means of the lateral threaded connections as well as via drilled channels on the bottom side.

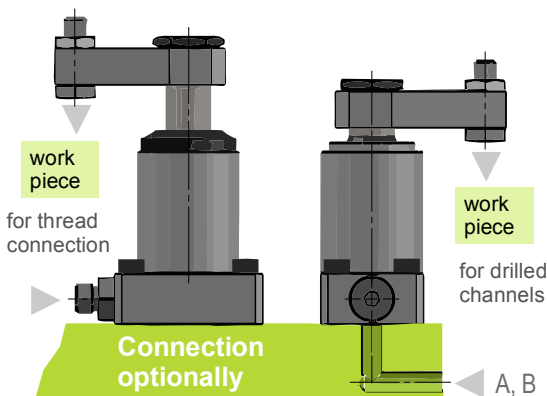

General Data	Unit	Value
Min. working pressure	[bar]	25
Max. testing pressure	[bar]	400
Max. temperature	[°C]	80
Max. volume flow	[l/min]	5

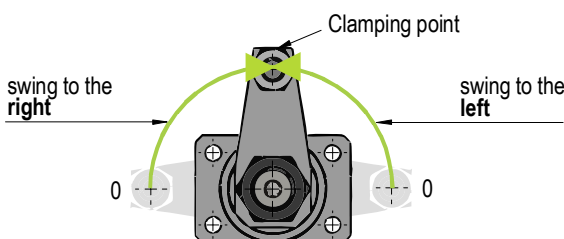

Recommendations for use:

Hydraulic swing clamps are used to clamp workpieces those are requiring a high degree of freedom during loading and unloading.

When installing the clamping cylinders, the flange surfaces should be adapted to the height of the workpiece.

These compact swing clamps are particularly suitable where no lateral forces are shall be introduced.

The actual clamping point should be in the middle of the clamping stroke.

If customer-supplied clamping arms are used, they should be equipped with a thrust bolt or hardened on the clamping / support surface.

Swing clamps can generate high forces. Workpieces and devices must be designed for such loads.

The cycle times for clamping and releasing should each not be less than 1 second. Otherwise, a throttling should be provided, preferably in the "B" channel. This can be done by restrictor plates, flow control- or throttle valves.

Dual connection option:

These clamping elements offer a dual connection option. In other words: they can be either threaded or O-ring/flange connection operated. The results are the following advantages:

1. When using the drilled channels, the thread connection can be used for bleeding or testing.
2. For the single-acting version, the integrated sintered air filter can be removed and the connection can be closed. Then the housing ventilation could takes place via drilled channels.
3. For speed control, an optional throttle screw can be used.



Further details can be found on the following pages.

Contact

iNOSOL GmbH
Frankfurter Str. 18
35315 Homberg/Ohm (Germany)

web: www.inosol.solutions
email: info@inosol.solutions
tel.: (+49) 6633 / 368 95 25

Dimensions

Details

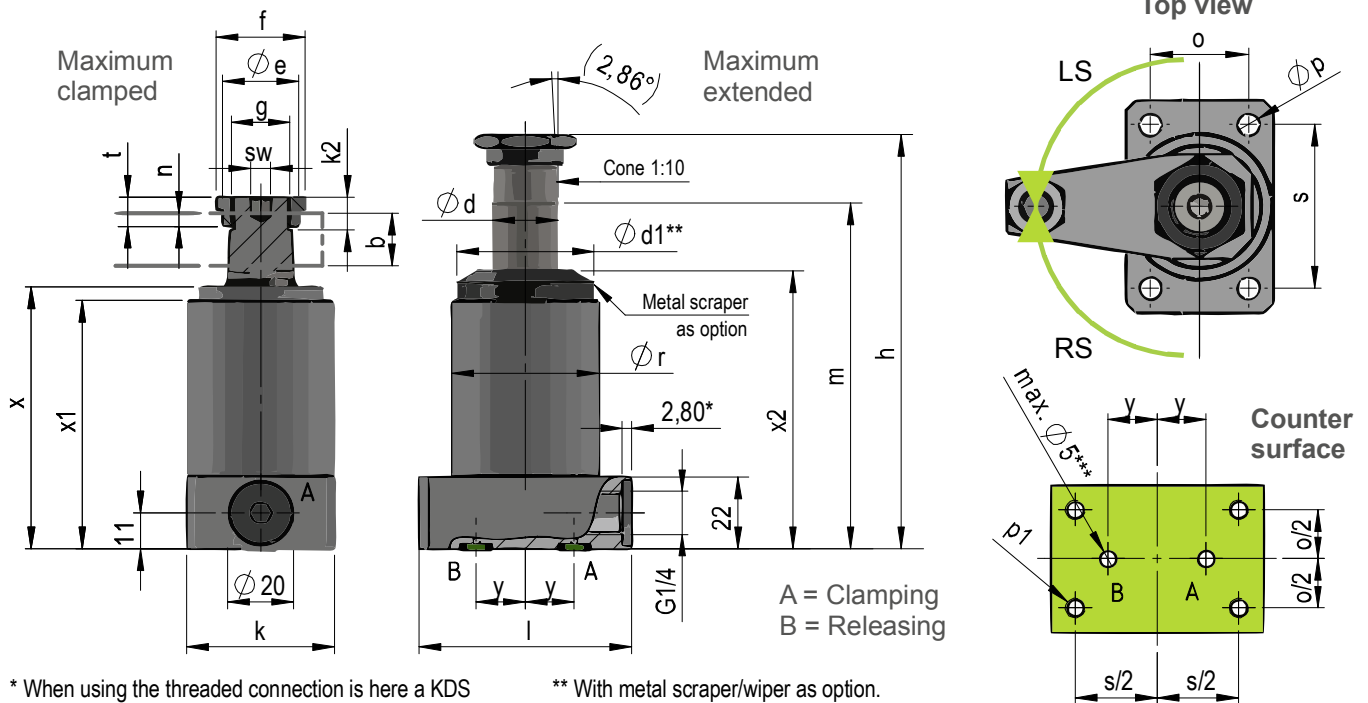

* When using the threaded connection is here a KDS sealing ring or profile sealing ring is recommended.

** With metal scraper/wiper as option.

*** Not required for threaded connection.

**** Notes on the flow rate on the following page.

The single-acting type only requires "A" and "B" can be used.

Size	Unit	1	2	3
Piston force at 300 bar	[kN]	5,30	13,56	21,20
Piston force at 100 bar	[kN]	1,77	4,52	7,07
Max. volume flow ****	[l/min]	2,40	3,80	4,80
D = piston-Ø (not show n)	[mm]	25	40	50
d = Rod-Ø	[mm]	20	32	40
SH = Clamping stroke	[mm]	11	13	15
GH = Complete stroke	[mm]	19	22	26
Ød1	[mm]	42	55	75
Øe	[mm]	23,5	33,5	45
f	[mm]	WS27	WS36	WS55
g	[mm]	M18x1,5	M28x1,5	M35x1,5
h (+2 max. ; depending on the screw-in depth of the nut)	[mm]	126,5	147,5	172
k	[mm]	45	63	80
l	[mm]	65	85	100
m (+/-1)	[mm]	106,5	120	139
o	[mm]	30	44	60
Øp	[mm]	6,5	8,5	13,5
p1	[mm]	M6	M8	M12
Ør	[mm]	45	60	80
s	[mm]	50	65	80
t	[mm]	9	10	11
x	[mm]	80	90,5	103
x1	[mm]	76	85	98
x2	[mm]	85	96	109
y	[mm]	15	28	31
sw	[mm]	WS6	WS8	WS10

0° pivoting angle	ISCC2520N-XXX	ISCC4032N-XXX	ISCC5040N-XXX
90° swing to the right	ISCC2520R-XXX	ISCC4032R-XXX	ISCC5040R-XXX
90° swing to the left	ISCC2520L-XXX	ISCC4032L-XXX	ISCC5040L-XXX

Part number definition: **ISCC2520R-1 0 2**
A : Size (Piston/Rod) **B** : Swing direction **C** : Metal scraper: Without = 0 / With = 1 **D** : Throttling screw without = 0 / with = 1 **E** : Double acting = 1 / Single acting = 2

Technical Data

Clamping force

Guide values for the resulting clamping force as a function of the one-sided clamping arm length

EW = Single acting
DW = Double acting

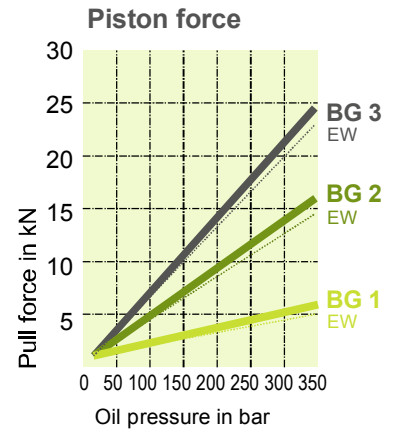
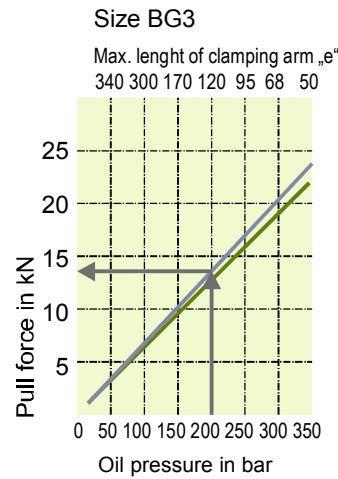
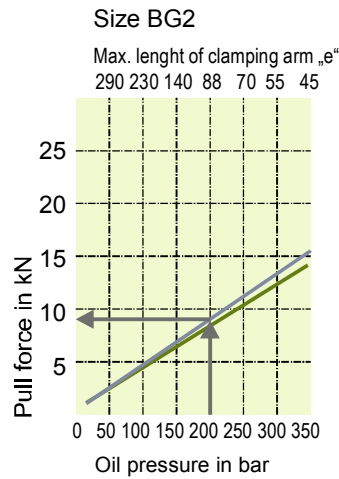
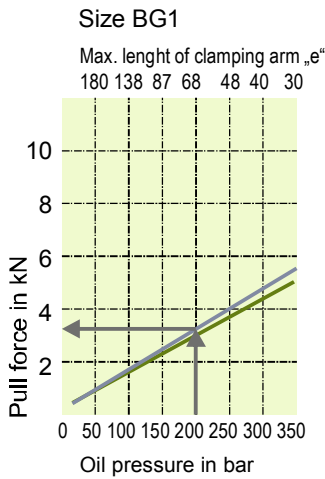

Cone/Clamping arm

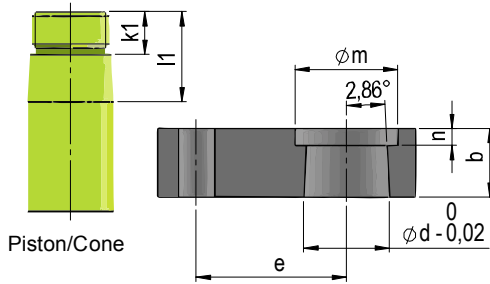

Size	Unit	1	2	3
For part number		ISCC2520...	ISCC4032...	ISCC5040...
b	[mm]	16	23	28
m	[mm]	24	34	46
n	[mm]	4	5	5
d	[mm]	20	32	40
k1	[mm]	10	12	12
l1	[mm]	21	28	34

e* = Only as coparsion value to table "clamping force"!

Clamping arms on request.

Optional accessories

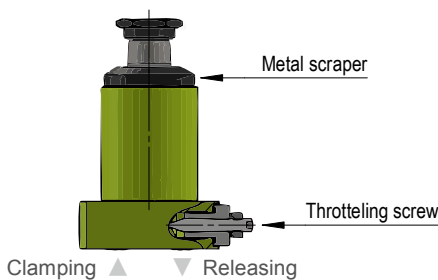

Metal scraper:

The use of the metal wiper is only recommended if **hot chips** are generated in the environment.

If aluminum / plastics or similar materials are processed, that also produce dusts, it is not recommended to use the additional scraper.

This also applies to the application under high vibration.

Throttling Screw:

The throttle screw can only be used in conjunction with the operation mode of the drilled channels. More details below.

Ventilation Screw:

Likewise, the integrated screw plug can be replaced through an INOSOL bleeding screw (IVS-002), to realize direct venting.



Throttling Screw

Part number:

ITSSC-002

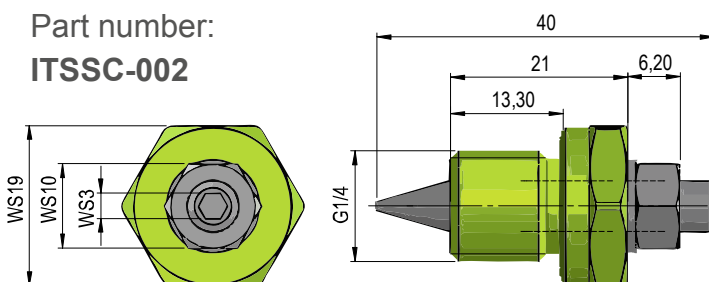

Application:

To apply a speed regulation or a synchronization of several clamping elements, the throttle screw can be used directly in the clamping element.

Material: Stainless steel / FKM

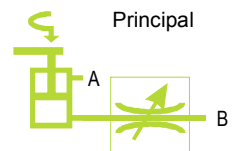

Note:

The throttle screw serves to reduce the volume flow in both directions and can only be used in the vent (B) channel. This is fluid mechanics wise and practically only useful to avoid a possible pressure boost.

Further Notes

Application



Mounting - clamping arm:

To protect the inner guide mechanism, it is recommended during assembly and disassembly of the clamping arm to hold the piston with an Allen key while tightening the fixing screw.

Mounting of the unit:

The bottom-side O-rings of the clamping unit are always to be mounted with the element.

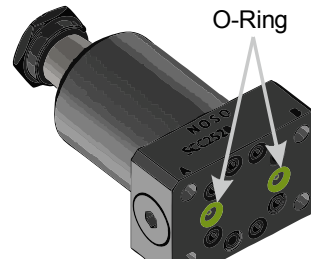

Note for use:

The clamping elements are only for hydraulic application. We recommend as medium Hydraulic oils according to DIN 51524.

Security Note:

There is a risk of crushing during operation. The accident prevention regulations must therefore be adhered.

Alternative Throttling

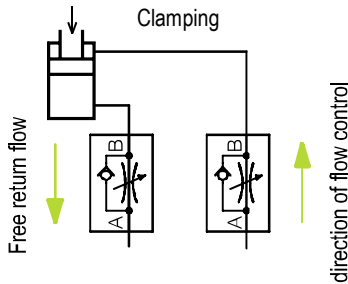

Speed regulation:

In case, that the tensioner is used in an existing hydraulic system, the throttling principal at the left can also be used. Here a throttle check valve in the line system is used.

Likewise, the throttle check valve shown on the right (ITV-001) can be used.

Especially when using long clamping arms the application of a speed throttling is recommend.



Note:

Throttling is not mandatory if the flow rate does not exceed 6 l/min and if no clamps are used, that produce an extremely high moment of inertia due to their size and weight. This must be determined on own responsibility.

Connection examples

Single Acting Connection

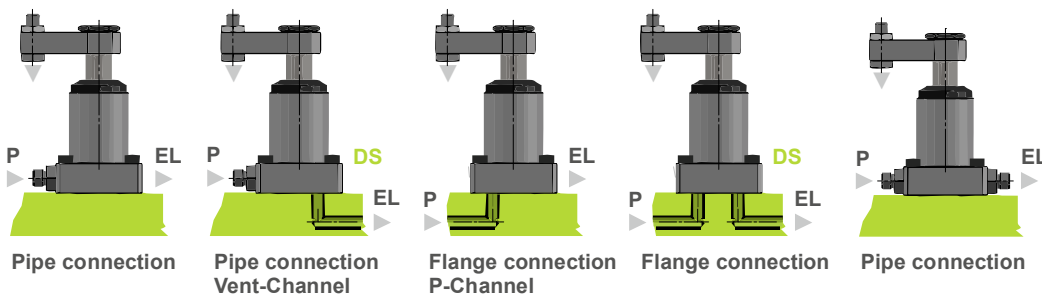

Double Acting Connection

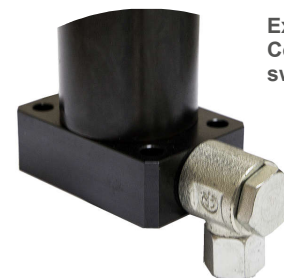
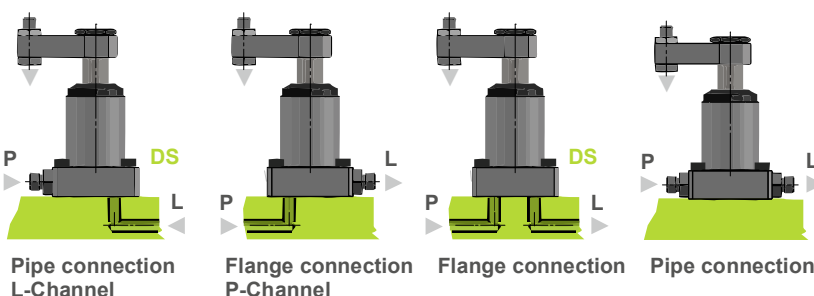

Example: Connection with swivel joint

Contact

iNOSOL GmbH
Frankfurter Str. 18
35315 Homberg/Ohm (Germany)

web: www.inosol.solutions
email: info@inosol.solutions
tel.: (+49) 6633 / 368 95 25