

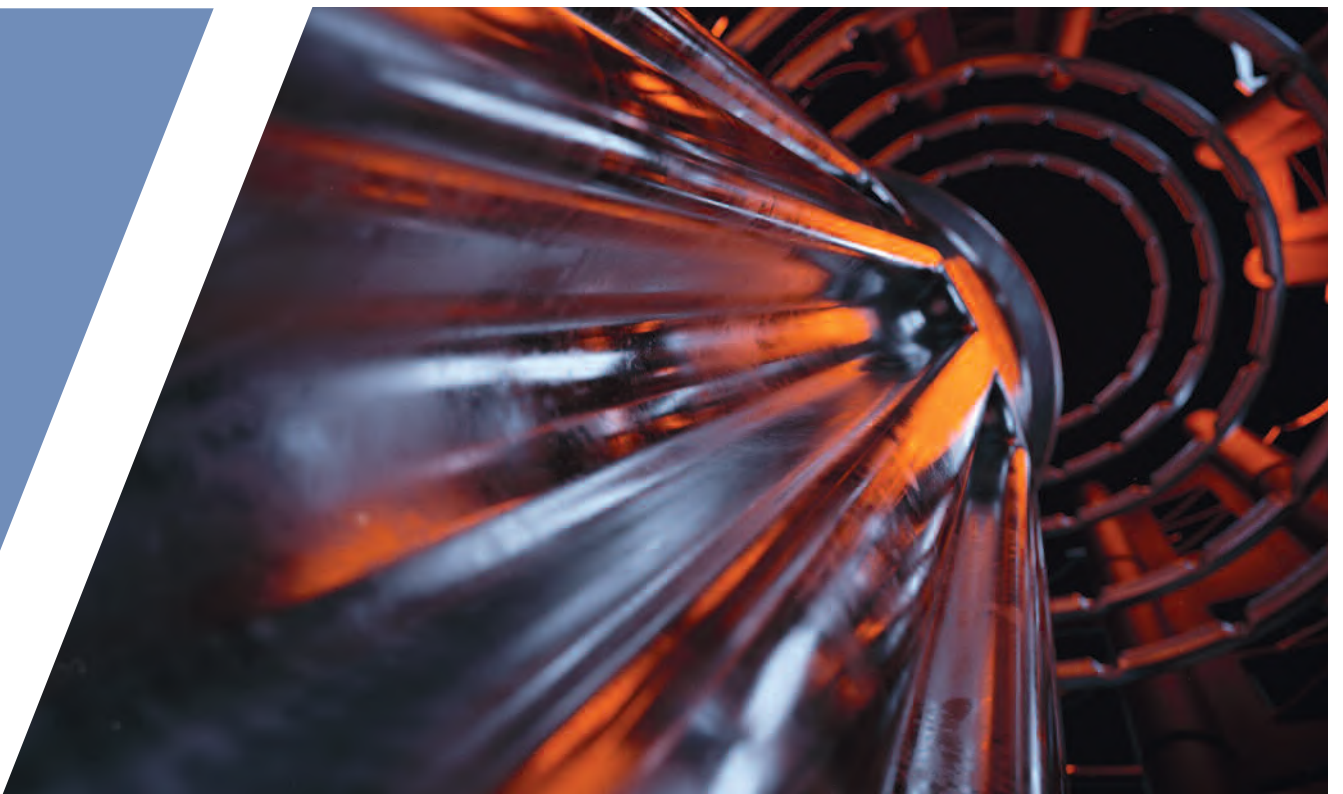

THE NEW **XELLETOR** SERIES  
The Next Evolution in Dewatering Technology



# THE NEW FLOTTWEG XELLETOR SERIES

## The Next Evolution in Centrifugal Sludge Dewatering

Sewage sludge dewatering offers a wide range of potential savings for the operators of sewage sludge treatment plants. Often, costs for transport and disposal of dewatered sewage sludge can amount to 80% of the operating costs in mechanical dewatering. Therefore, the decision to invest in a powerful and, above all, economic dewatering system is highly important. Since dewatering sludge means reducing the amount of sludge to be disposed of, this naturally leads to reduced disposal costs.

**Depending on the capacity of your system, just a 1 percent increase in dry matter in the dewatered sludge may result in annual cost savings in the hundreds of thousands.** However, the dry matter content is not the only critical point – polymer consumption, the solids charge in the centrate (in the separated liquid) and energy consumption are also crucial factors when considering the efficiency of the entire process.

Flottweg has developed a unique centrifuge concept specifically designed for the high-efficiency dewatering of sewage sludge: The Flottweg Xelletor Series.

The dewatering efficiency of our machine is considerably higher than that of our previous models. Moreover, the Xelletor series machines **set new standards for capacity, dry matter as well as polymer and energy consumption.** This has a very positive impact on your sludge disposal process, regardless of whether you dispose of the sludge or thermally treat it.

# XELLETOR

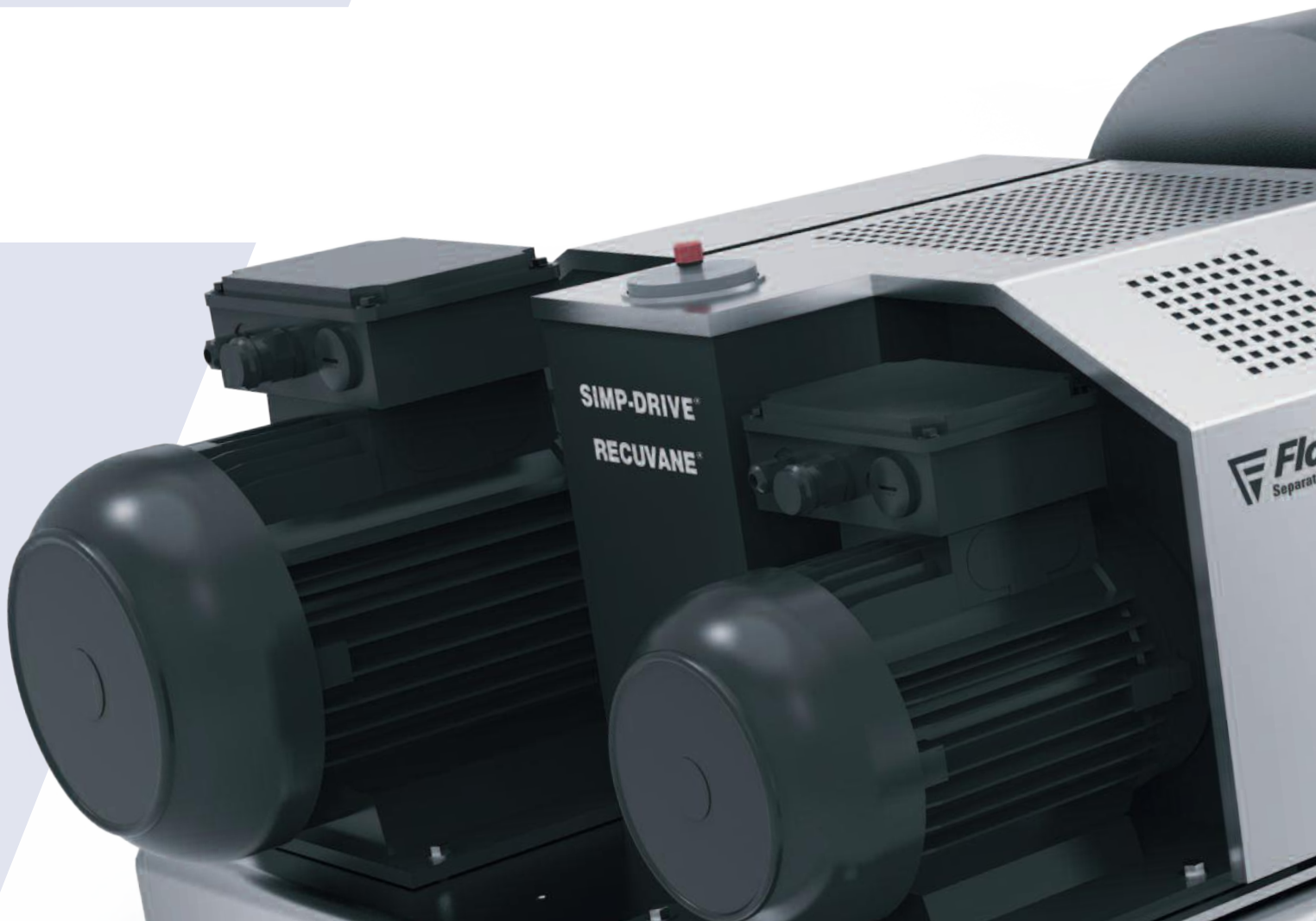

## The new Flottweg Xellektor Series – Xtra performance and reduced consumption

We have set the bar high – by comparing the new Xellektor system to our high-performance C series.

### Xtra dewatering performance

up to 10% less sludge due to a high dry-matter content in the dewatered sludge –  
thus high savings potential

### Xtra polymer savings

up to 20% savings in polymer consumption

### Xtra capacity

up to 15% more capacity

### Xtra energy savings

additional energy savings of up to 20%



# THE MOST ECONOMIC SOLUTION FOR SLUDGE DEWATERING

## Optimize Your Process – Save Energy and Costs

In order to find the optimum and, above all, most economical solution for your dewatering process, you should always consider all the important parameters, which include **dry-matter content and capacity**

**as well as polymer and energy consumption.**

This is where the greatest potential savings can be realized!



### XTRA ENERGY

Thanks to our extra-deep pond concept, you will save **up to 20% more energy** compared to our conventional series. Depending on the capacity, the specific energy consumption for sludge dewatering is just 0.7 kWh/m<sup>3</sup>. Typically, these top values can only be bettered via sludge thickening.



### XTRA DRY MATTER

The dewatering result strongly depends on the characteristics of the sludge to be treated. Generally, between 20 and 40% TS (**dry matter**) can be achieved. Compared to conventional high-performance centrifuges, the Xelleter system can achieve a 2% increase in the dry-matter content. As a result, the volume of **dewatered sludge is reduced by up to 10%**.

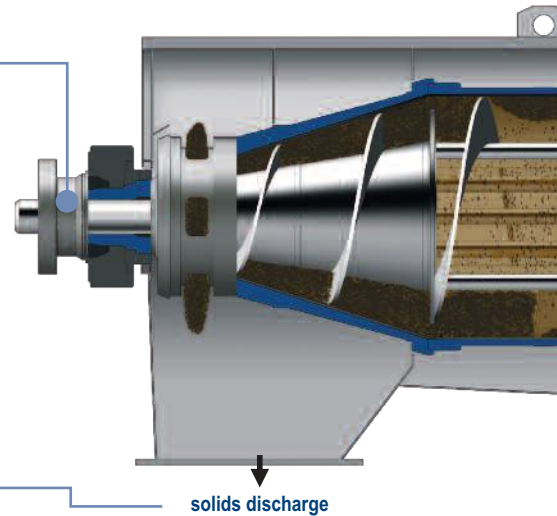



### XTRA POLYMER SAVINGS

*Polymer savings* of up to **20%** are possible with the same dry-matter content and quality of the dewatered sludge.



### XTRA CAPACITY

Using the Xellektor system, it is possible to increase the *capacity* of your unit by an additional **15%** with the same bowl diameter. This makes the Xellektor system an attractive option when it comes to refitting your plant.

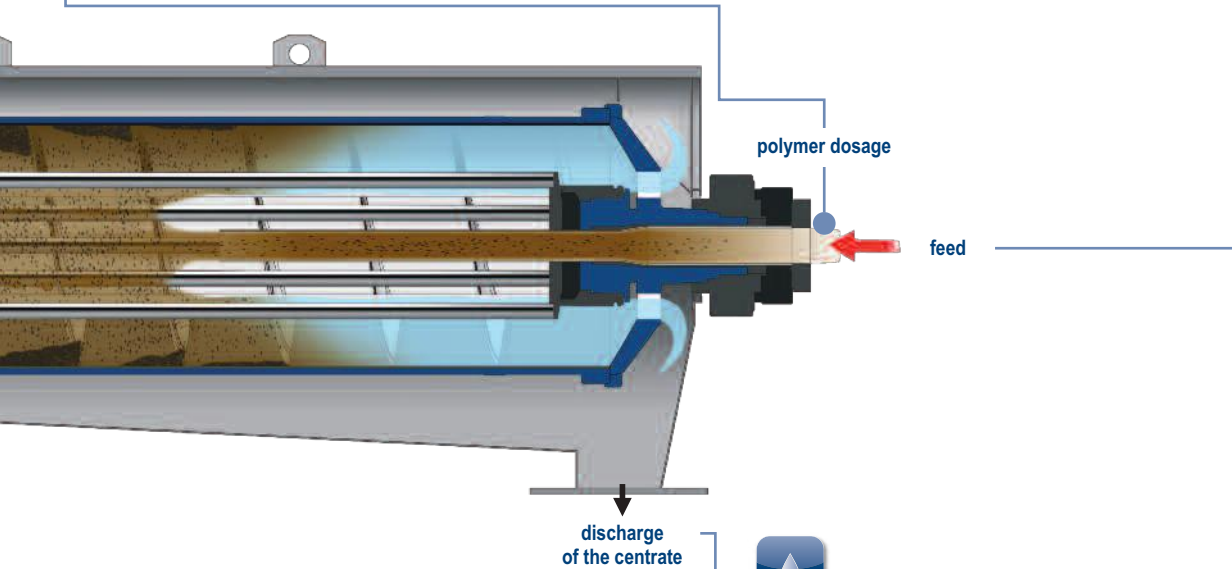

### XTRA CLEAN

In sludge dewatering, the *separation efficiency* of our centrifuges is in general greater than **99%**, which reduces back-contamination in the centrate and thus saves additional costs.

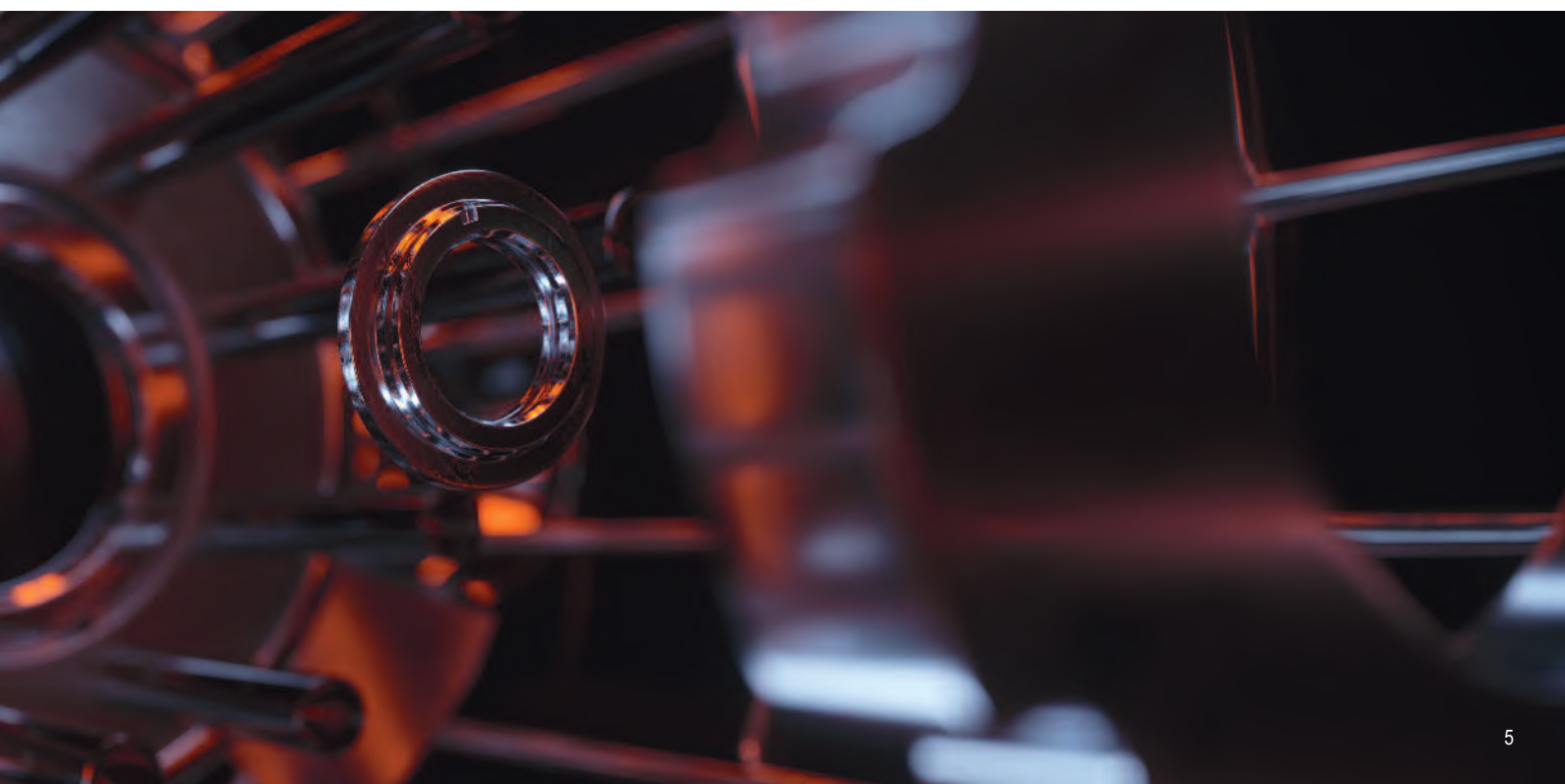

# THE SECRET OF THE XELLETOR SYSTEM

## The Evolutions of the Rotor and Scroll

With the ultimate goal of maximum separation efficiency, the existing centrifuge concept has been continuously and radically analyzed by Flottweg engineers and technicians alike. At the heart of this continuous evolution is our revolu-

tionary redesign of the centrifuge's core component consisting of the rotor and the scroll. Inspired by the light-metal design of racing cars and bikes, we conceived the idea to build a scroll with the highest degree of stiffness without a scroll body. The resulting Xelletor series is therefore the latest evolution in centrifugal dewatering.

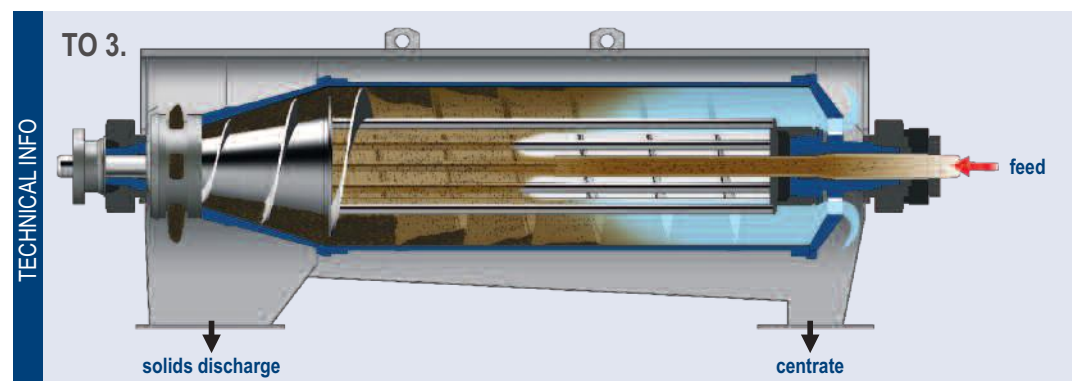
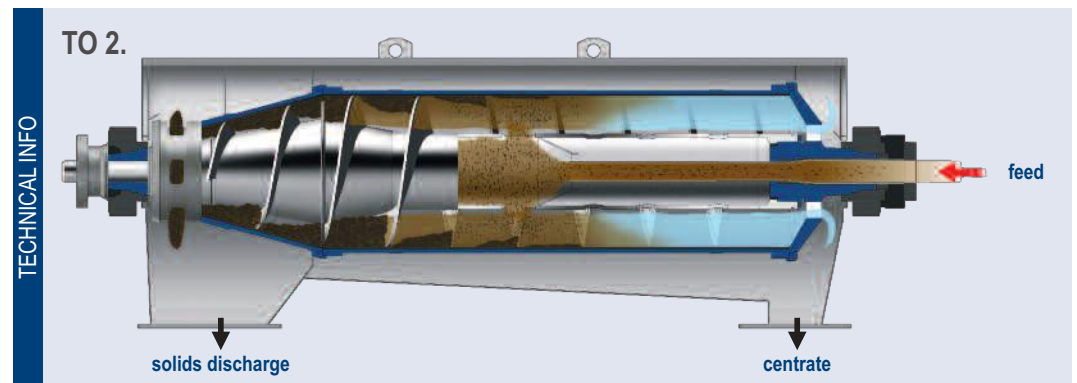
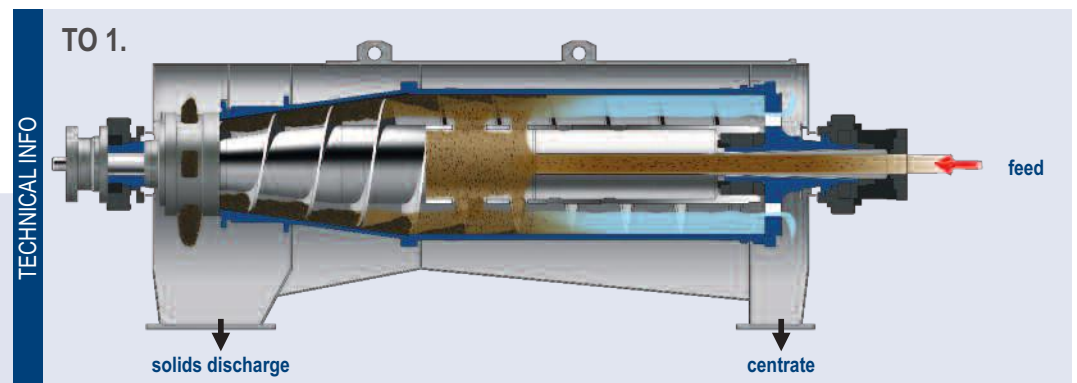

## 1. THE BASIS – EFFICIENT SOLID-LIQUID SEPARATION

### Feed

The liquid mixture to be separated is fed through a stationary pipe into the machine. The mixture enters the cylindrical part of the bowl through the scroll body and is then accelerated.

### “Pond”

Due to centrifugal force a liquid ring is built inside the machine. The thickness of the ring is called the pond depth. The solids, or heavy phase, form a concentric layer at the bowl wall. The solids are discharged from the machine by the scroll via the conical part. The separated liquids are discharged through a weir.

### Solids Discharge

The cone angle and the weir limit the depth of the “liquid pond”. For example, a flat pond is optimal for dewatering mixtures containing granular solids.

## 2. FLOTTWEG C-SERIES – OPTIMUM PERFORMANCE FOR HIGH-EFFICIENCY DEWATERING

### Feed Geometry

The holes in the body of the scroll have hardfacings to increase wear resistance. The geometry of the holes is adapted to ensure a soft entry for the liquid. This has a positive impact on the efficiency of the flocculants, and therefore also on separation efficiency.

### Deep Pond

Thanks to the steep cone in combination with the slim body of the scroll and the respective weir diameter, the pond depth is increased. This deep pond provides additional compression on the solids. Optional windows in the scroll inserts optimize the liquid flow (“axial flow”) and thus the separation efficiency. The separated liquids flow out of the machine in a “softer” way.

### Pressing

In combination with a weir plate, the steep cone located in the scroll body literally presses out the sludge before it is discharged from the machine.

## 3. THE XELLETOR EVOLUTION



### XELLETOR DESIGN

In the Xelletor system, the liquid is accelerated directly in the centrifuge zone. There is no scroll body; the liquid is accelerated softly, which results in a reduced consumption of flocculants. There is no wear at the feed zone; thus, hardfacings are not required in this zone.



### SUPER-DEEP POND

In case of conventional decanter centrifuges, the body of the scroll limits the pond depth. Thanks to the Xelletor construction, these limits no longer exist. For the first time, the super-deep pond is possible, which has a positive impact on compression, the clarification zone and therefore separation efficiency.



### FLOW OPTIMIZED

Besides an optimized energy balance, the flow conditions within the centrifuge have also been optimized. Higher capacities are therefore possible with the same rotor diameter.



### PRESSING

In order to further increase the compression effect, the Xelletor system is also equipped with a weir plate.

# EFFICIENT, ECONOMIC, COMFORTABLE

## The Xelletor Factors at a Glance

Sludge dewatering on a new level: The Xelletor series combines our most recent sludge dewatering technologies and know-how. Over time, we have been meticulously collecting and evaluating both our customers' demands and our process experiences. We have learned what is important to you. Based on this knowledge, we are continuously improving the per-

formance of our centrifuges, while always keeping in mind economic efficiency when optimizing your processes, as well as the price performance ratio of our machines. Furthermore, you will benefit from the typical advantages offered by centrifugal sludge dewatering.



### WATERTIGHT DESIGN

- Closed construction
- Excellent shielding of the working environment against odor emissions and sewage sludge aerosols



### SIMPLE, INTELLIGENT, MODULAR, POWERFUL

- Powerful Flottweg Simp Drive®
- Economic due to its intelligent combination of rotor and scroll drives; conversion losses are reduced
- Machine can be emptied at standstill because the scroll rotates independently from the rotor (no disassembling of system components necessary, e.g., after a power failure)
- Fully developed and manufactured by Flottweg without bought-in parts, the components are therefore optimally dimensioned and adjusted to the machine.
- High availability in the event of maintenance and service



### HIGHER PERFORMANCE AND LOWER CONSUMPTION

Thanks to the radically new Xelletor scroll design, better separation efficiency is possible due to

- optimized flow conditions inside the machine
- maximum compression on the solids thanks to the super-deep pond and weir plate for maximum dry-matter content





### MASTER SAVER

- Additional energy recovery thanks to the Flottweg Recuvane® System



### CENTRIFUGAL ACCELERATION

- G-forces of up to 3500 in the Xelletor
- Due to these high g-forces, the sludge is pressed out efficiently, thus resulting in an additional dewatering effect.
- In combination with the super-deep pond, the g-force results in a high g-volume and thus a maximum separation effect.



### AUTOMATIC IS GOOD!

- Fully automatic adjustment of the bowl and differential speed produces optimum dry matter levels in the dewatered solids at any time, even in case of varying conditions in the feed.
- Already 4.0-compliant – all options for remote monitoring and maintenance are available on request.
- Optional – automatic dosage of flocculants with real-time monitoring; polymer consumption is also reduced.
- Individual integration of the centrifuge control system into the main control system for maximum efficiency and security of your system

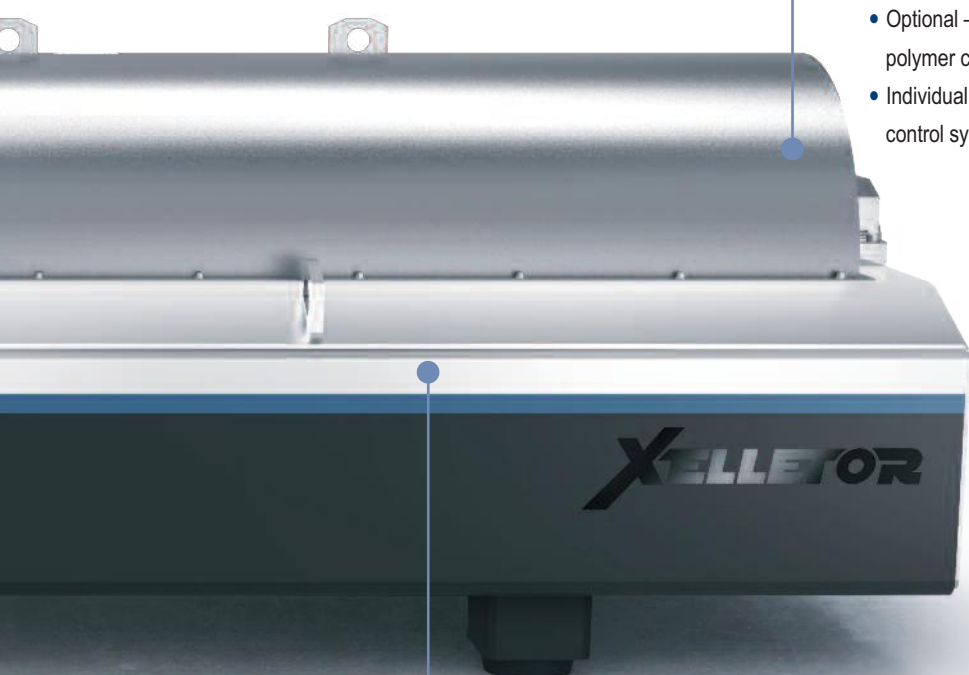

### STURDY AND RESISTANT

- Highly efficient wear protection for the scroll inserts, rotor and discharge system
- No more wear at the feed zone of the scroll body – there is no scroll body in the Xelletor system!



### INTELLIGENT DESIGN

- Easy maintenance on-site due to simple replacement of the wear parts
- Quick assembly and disassembly of the rotor and scroll helps to reduce service and maintenance costs

# THE FLOTTWEG XELLETOR SERIES

## Technical Data



### GUARANTEED FLOTTWEG QUALITY

Typical “Made in Germany” quality: We have a very clear idea about quality and do not make any compromises here. Often, our customers have to deal with aggressive substances contained in wastewater. Therefore, we exclusively use rust-proof and acid-resistant materials for wetted parts. Our optimally equipped machines will withstand your demands permanently – in extreme cases 24/7. Our strict quality controls (DIN ISO 9001:2015) as well as the ability to track all critical components provide additional product safety.



### OUR SERVICE – ALWAYS AVAILABLE FOR YOU

Almost 900 employees located globally throughout our network of more than 60 sales and service points are ready to assist you. We not only strive to provide excellence when selecting and dimensioning our systems, we are ready to assist you also afterward, whenever you need us – in more than 100 countries worldwide.



### Any questions? Then don't hesitate to contact us!

We will show you how you can save costs and energy when using machines from the Flottweg XelleTOR Series. Together with our experts, we'll discover your precise optimization potential.

For more information, please visit our website: [www.flottweg.com](http://www.flottweg.com)



TECHNICAL DATA FOR THE FLOTTWEG XELLETOR SERIES*			
Type	X4E-4	X5E-4	X7E-4
Materials	All wetted parts are made of rust-proof and acid-resistant stainless steel, e.g., 14463 (Duplex) and 1,4571 (AISI 316Ti).		
Dimensions (L x W x H)	3520 x 1140 x 1030 mm / 140" x 45" x 40"	4100 x 1550 x 1200 mm / 161" x 61" x 48"	4800 x 1720 x 1390 mm / 189" x 68" x 58"
Gross weight	2760 kg / 6100 lb	5030 kg / 11100 lb	8200 kg / 18100 lb
Motor for bowl drive	22 – 30 kW / 30 – 40 hp	45 – 75 kW / 60 – 100 hp	75 – 110 kW / 100 – 150 hp
Motor for scroll drive Flottweg Simp Drive®	7.5 – 11 kW / 10 – 15 hp	15 kW / 20 hp	30 kW / 40 hp
Capacity	20 – 50 m³/h / 90 – 220 gpm	30 – 70 m³/h / 130 – 300 gpm	60 – 140 m³/h / 260 – 600 gpm

\* The listed figures are merely guidelines. Actual capacity depends on the individual characteristics of the product. Subject to technical changes.

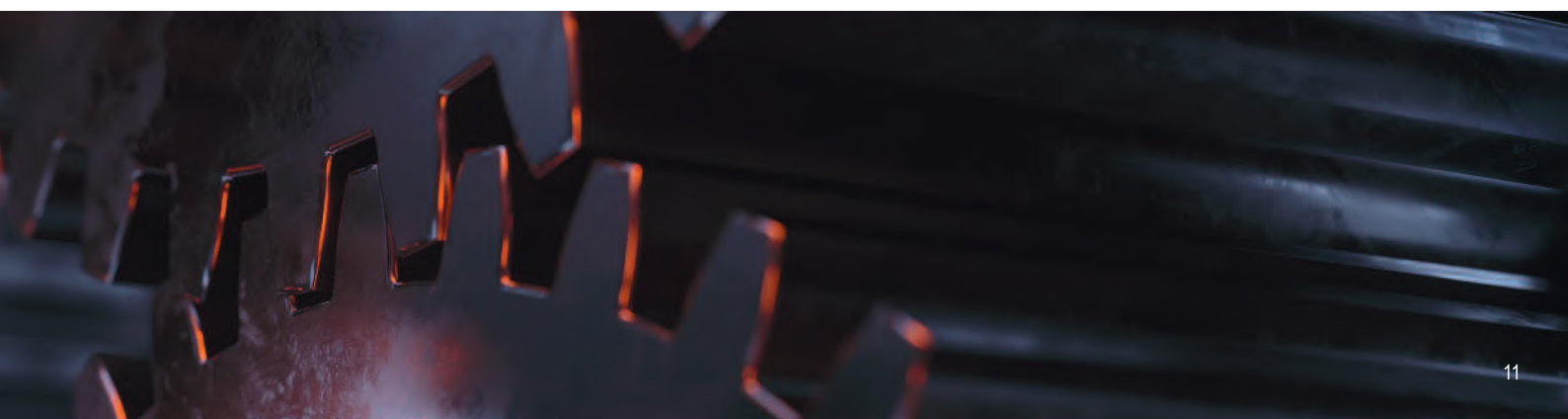

# Flottweg Separation Technology – Engineered For Your Success



Flottweg SE  
Industriestraße 6-8  
84137 Vilsbiburg  
Deutschland (Germany)

Tel.: +49 8741 301-0  
Fax: +49 8741 301-300

[mail@flottweg.com](mailto:mail@flottweg.com)  
[www.flottweg.com](http://www.flottweg.com)

REPRESENTATIVE