

Applicable for:

Plastic Hood	09pos. (Part no.16-001750/16-001810)
9 - 50pos.	15pos. (Part no.16-001760/16-001820)
SnapLock	25pos. (Part no.16-001770/16-001830)
(metal. and black vers.)	37pos. (Part no.16-001780/16-001840)
	50pos. (Part no.16-001790/16-001850)

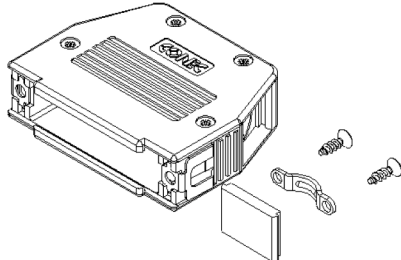

Component overview:

- 1 hood,
- 6 countersunk head screws,
- 1 cable strain relief,
- 2 blanking plugs (1 blanking plug for 9 / 15 pos).

Dimensions in mm

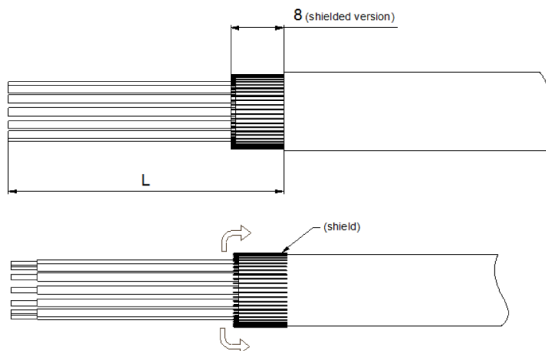

Strip cable as shown in the drawing.

Dimension L:

- 9 / 15pos: 30-33mm
- 25 / 37 / 50pos: 35-40mm

Stripping length of the stranded conductors is dependent on the connector contact type.

Slide the shield braid (if applicable) over the cable jacket.

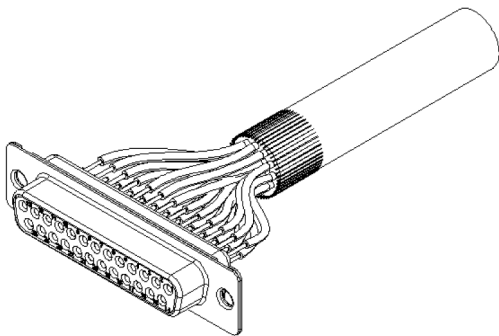

For solder type contacts:

- Apply heat to the contact and allow solder to flow into the solder pocket hole.
- Insert the conductor and solder it to the contact.
- Remove excessive solder.

For crimp type contact:

- Insert conductor into the contact crimp barrel as far as it will go.
- Crimp the contact using an appropriate crimping tool.

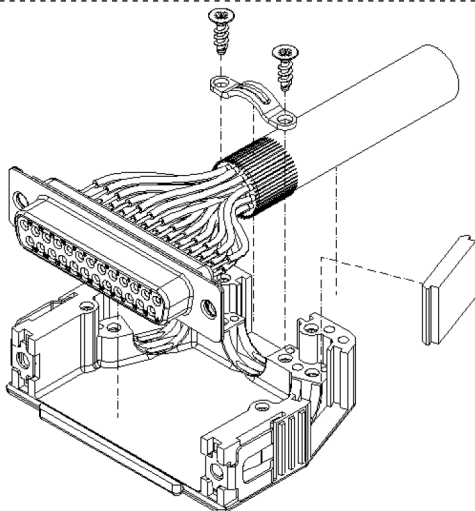

Close the unused slots with blanking plugs.

Insert connector into hood.

Insert cable into cable opening and secure it with the cable strain relief.

Take care that cable jacket and shield braid (if applicable) is completely under the cable strain relief.

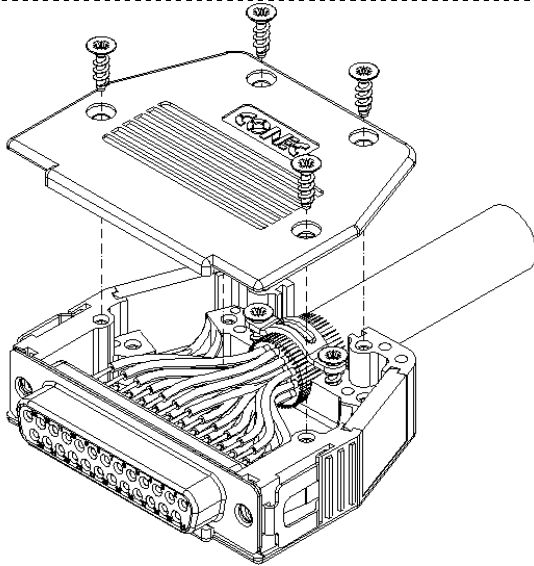

Place the hood lid on the hood assembly and secure it with the countersunk head screws, supplied.

Application hood to hood

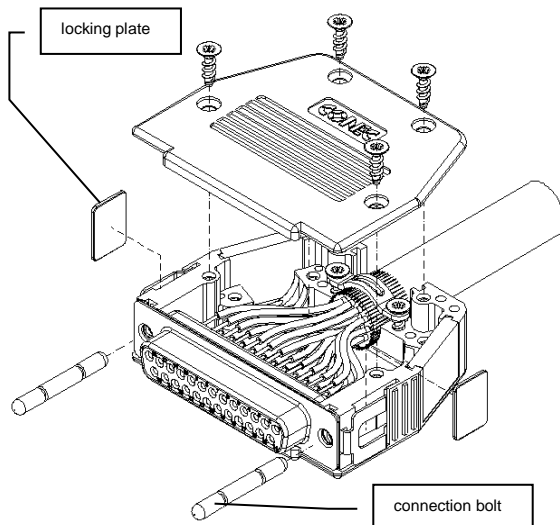

For Hood to Hood application (Part No: 16-002200)

Insert the connecting pins through the mounting holes of the D-Sub connector into the hood until they lock.

Insert the locking plates in the gaps of SnapLock-clips. The orientation of the plates shall be as shown on the picture (the short sides of the plates to be facing the bottom and the top of the gap).

Place the hood lid on the hood assembly and secure it with the countersunk head screws, supplied.

The information given here is subject to change without notice.